



# **CLEAN AIR SOLUTIONS AIR CLEANERS & FILTER HOUSINGS**

**ELECTRO-AIR CANADA  
351 North Rivermede Road  
Concord, Ontario, Canada, L4K 3N2**

**416-213-5636  
800-267-8305  
info@fiveseasonsaircleaners.com  
www.fiveseasonsaircleaners.com**

**January 2022**



# TABLE OF CONTENTS

<b>SECTION</b>	<b>PRODUCT DESCRIPTION</b>	<b>PAGE</b>
<b>1</b>	<b>HEPA AIR CLEANERS</b>	
	• Portable HEPA, UVC, PCO Air Purifier (P900)	3
	• Commercial Portable HEPA, UVC, PCO Air Purifier (SA900)	5
	• Duct or Wall Mount HEPA, UVC, PCO Air Purifier (DM900UV-VO-VS)	7
	• Duct or Wall Mount HEPA (HEPADM400VS)	9
	• True HEPA Air Cleaners (HEPA350, 450, 550-3, 650)	11
	• Commercial Portable True HEPA on Wheels (HEPA375VSC)	13
	• Commercial/ Industrial Mobile True HEPA on Wheels (HEPA600M-3)	15
<b>2</b>	<b>ELECTRONIC AIR CLEANERS</b>	
	• Portable Electronic, Negative Ionizer & VOC Filters (490, 590, 680, 690, 890)	17
	• Duct Mount Electronic Air Cleaners (SASD Series)	19
	• Return Grille Mount Electronic Air Cleaner (GM20AS)	21
	• Ceiling Mount Electronic Air Cleaners (SSCB7, SSCB15)	23
	• Industrial Self-Contained Electronic Air Cleaner (SC924-1)	25
	• Industrial Mobile Particulate Removal System (MPRS1000)	27
<b>3</b>	<b>MEDIA AIR CLEANERS</b>	
	• Media Retrofit Air Cleaner, MERV 11 (MU Series)	29
	• Media Retrofit Air Cleaners, MERV 14 (14MU Series)	31
	• Media New Construction Air Cleaner, MERV 11 (NC Series)	33
	• Perfect Clean-Fit Media Air Cleaners, MERV 11 (MA11 Series)	35
	• Media Air Cleaner, Top Loading, MERV 11 (MEDIA-1625-TL)	37
	• Light Commercial Over-sized Media Air Cleaner, MERV 11 (MF3225)	39
	• Right Angle Media Air Cleaner, MERV 11 (RAM2000)	41
<b>4</b>	<b>RISERS, PLATFORMS, FILTER HOUSINGS &amp; COIL CASES</b>	
	• Upflow Bottom Side Return Bases For Gas Furnaces (USBG Series)	43
	• Perfect Platform for Gas & Electric Furnaces (FB Series)	44
	• Filter Housings for Electric Air Handlers, MERV 11 Filter (FHE-7 Series)	45
	• Filter Housings for Electric Air Handlers (FHE Series)	46
	• Filter Housings for Gas Furnaces, MERV 11 Filter (FHG-7 Series)	47
	• Filter Housings for Gas Furnaces (FHG Series)	48
	• Downflow Filter Housings (CFHG Series)	49
	• Plenum Access Coil Cases (CC Series)	50
<b>5</b>	<b>REPLACEMENT FILTERS &amp; DAX DETERGENT</b>	
	• Universal Series, MERV 11, 4 <sup>3</sup> / <sub>8</sub> " Filters (MFH Series)	51
	• Proprietary Signature Series, MERV 11, 5 <sup>1</sup> / <sub>4</sub> " Filters (M- Series)	52
	• Proprietary Green Series, MERV 14, 5 <sup>1</sup> / <sub>4</sub> " Filters (G- Series)	53
	• DAX Air Cleaner Detergent	54

## PORTABLE HEPA AIR CLEANER WITH ULTRAVIOLET LIGHT & PHOTO CATALYTIC FILTER

### Description

- The 5-in-1 Portable True HEPA Air Cleaner by Electro-Air offers the ultimate in air filtration and sterilization. This patent-pending combination uses HEPA, UVC Germicidal Light (non ozone producing) and Photo Catalytic Oxidation. It removes and destroys allergens, lung damaging atmospheric dust, biological and chemical contaminants and odours, such as toluene, benzene, cooking odors, tobacco & cannabis smoke and odours, bacteria, viruses, mold and lots more.
- Ideal for residential and commercial applications where there are allergy/ respiratory sufferers, new construction odours, smokers, pets, mold, water & sewer damage, garbage disposal rooms, cannabis manufacturing processes and more.

### Standard Features

- Carbon Prefilter protects the HEPA filter while removing lint, hair and larger particles.
- Long-life, 99.97% HEPA Media Filter removes particles 0.3 micron (1/84,000 of an inch) and larger such as atmospheric and household dust, coal dust, insecticide dust, mites, pollen, mold spores, fungi, bacteria, viruses, pet dander, cooking smoke and grease, tobacco and cannabis smoke particles and more. The HEPA filter becomes more efficient as it becomes dirtier with time.
- Two UVC Germicidal Lights are enclosed in a Reflector which intensifies the UV rays.
- Unique CinQuartz<sup>®</sup> Photo Catalytic Oxidation Filter (PCO) has a very high surface exchange capability and allows UV light into the mass of the material — means there is absorption throughout the whole CinQuartz filter instead of just on the surface. The combination of the UVC light and the CinQuartz<sup>®</sup> decomposes organic materials into basic molecules such as H<sub>2</sub>O and CO<sub>2</sub>.
- Carbon/ Potassium Permanganate Final Filter for removal of Volatile Organic Compounds (VOC's) and light gases.
- Powerful energy efficient, variable speed European motor delivers up to 250 CFM of pure air.
- Plug-in Power Cord provides convenient electrical connection.
- Castors allow easy maneuvering from room to room.



### POLLUTION CHART

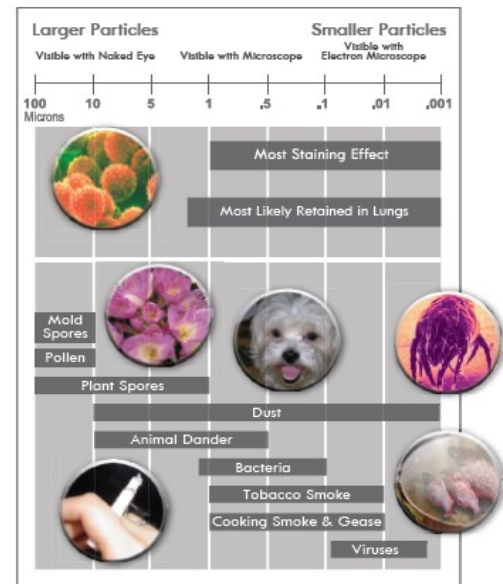

### Cabinet Construction

- Sleek looks that are aesthetically pleasing, blend nicely with any decor.



## SPECIFICATIONS

MODEL	EAP900	
<b>Air Flow: Variable Speed Control</b>	Up to 250 cfm	Up to 425 m <sup>3</sup> /hr
<b>Carbon Prefilter: DM900-0855</b> Removes lint and large particles	Replace every 3-6 months	
<b>Long-Life, 99.97% HEPA Media: DMH4-0400</b> Removes pollutants 0.3 micron	40 ft <sup>2</sup> Replace every 2-4 years	3.7 m <sup>2</sup> Replace every 2-4 years
<b>Germicidal UVC Light: DM900-0191</b> Strongest light intensity kills bacteria, viruses, mold, fungi, allergens	2 Bulbs Replace every 13,000 hours or 2-3 years	
<b>CinQuartz® Substrate PCO Filter: DM900-0450</b> Removes Volatile Organic Compounds (VOC's) & kills viruses	Replace every 13,000 hours or 2-3 years	
<b>Carbon/ Potassium Permanganate Final Filter: DM900-0810</b> Removes VOC's and light gases	Replace every 1-2 years	
<b>Complete 2-3 Year Maintenance Kit: DM900-1003</b> Contains 1 HEPA Filter, 4 Carbon Prefilters, 2 UVC Lamps, 1 Photo Catalytic Oxidation (PCO) Filter, 2 Carbon/ Potassium Permanganate Final Filters, gloves	Replace every 2-3 years	
<b>Cabinet Dimensions: H x W x D</b>	29.5 x 16.25 x 12.75 in	74.9 x 41.3 x 32.4 cm
<b>Input Voltage</b>	120 v 60 hz	
<b>Power Consumption</b>	200 watts	
<b>Power Cord</b>	10.0 ft	3.05 m
<b>Unit Weight</b>	47 lbs	21.3 kg

### HOW IT WORKS

The air passes through a pleated Carbon Prefilter which removes lint and large particles to extend the life of the HEPA filter.

Smaller particles then pass through a long-life, 99.97% HEPA (High Efficiency Particulate Air) Media Filter which captures particles 0.3 micron (1/84,000 of an inch) and larger.

The clean air passes through a reflection chamber where two Ultraviolet Germicidal Lamps emit powerful UVC light rays which are designed to kill or inhibit bacteria, viruses, mold, fungus and microbial growth. These are non-ozone producing lamps. The Ultraviolet Lights are also used to activate the unique CinQuartz Media located below the UVC lamps.

The Photo Catalytic Oxidation (PCO) Filter is a unique media coated with nanoparticles of Titanium Dioxide (TiO<sub>2</sub>). The combined action of the UVC light and the TiO<sub>2</sub> decomposes organic materials into basic molecules such as H<sub>2</sub>O and CO<sub>2</sub> and reduces odours and VOC's as a result.

A Carbon/ Potassium Permanganate Final Filter further reduces VOC's and light gases.

Clean air is discharged.

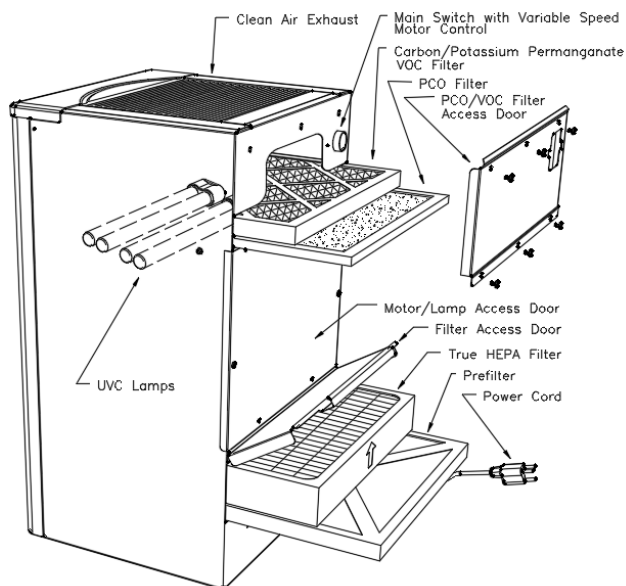

### ELECTRO-AIR CANADA

351 North Rivermede Road, Concord, Ontario, Canada L4K 3N2

Tel: (416) 213-5636 Fax: (416) 213-5593

Toll Free: (800) 267-8305

info@fiveseasonsaircleaners.com

www.fiveseasonsaircleaners.com



**PROUDLY MADE IN CANADA**

## COMMERCIAL PORTABLE HEPA AIR CLEANER WITH ULTRAVIOLET LIGHT & PHOTO CATALYTIC FILTER

### Description

- The 5-in-1 Commercial Portable True HEPA Air Cleaner by Electro-Air offers the ultimate in air filtration and sterilization. This patent-pending combination uses HEPA, UVC Germicidal Light (non ozone producing) and Photo Catalytic Oxidation. It removes and destroys allergens, lung damaging atmospheric dust, biological and chemical contaminants and odours, such as toluene, benzene, cooking odors, tobacco & cannabis smoke, bacteria, viruses, mold and lots more.
- Ideal for light commercial applications where there are allergens, bacteria, viruses, new construction/ renovation odours, tobacco & cannabis odours, animals, food & spice odours, mold, water and sewer damage.

### Standard Features

- Carbon Prefilter protects the HEPA filter while removing lint, hair and larger particles.
- Long-life, 99.97% HEPA Media Filter removes particles 0.3 micron (1/84,000 of an inch) and larger such as atmospheric and household dust, coal dust, insecticide dust, mites, pollen, mold spores, fungi, bacteria, viruses, pet dander, cooking smoke and grease, tobacco & cannabis smoke particles and more. The HEPA filter becomes more efficient as it becomes dirtier with time.
- Two UVC Germicidal Lights are enclosed in a Reflector which intensifies the UV rays.
- Unique CinQuartz<sup>®</sup> Photo Catalytic Oxidation Filter (PCO) has a very high surface exchange capability and allows UV light into the mass of the material — means there is absorption throughout the whole CinQuartz filter instead of just on the surface. The combination of the UVC light and the CinQuartz<sup>®</sup> decomposes organic materials into basic molecules such as H<sub>2</sub>O and CO<sub>2</sub>.
- Carbon/ Potassium Permanganate Final Filter for removal of Volatile Organic Compounds (VOC's) and light gases.
- Powerful energy efficient, variable speed European motor delivers up to 250 CFM of pure air.
- Plug-in Power Cord provides convenient electrical connection.



### Cabinet Construction

- One piece wrap, steel cabinet has powder-coat paint finish to provide long life and durability.

### POLLUTION CHART

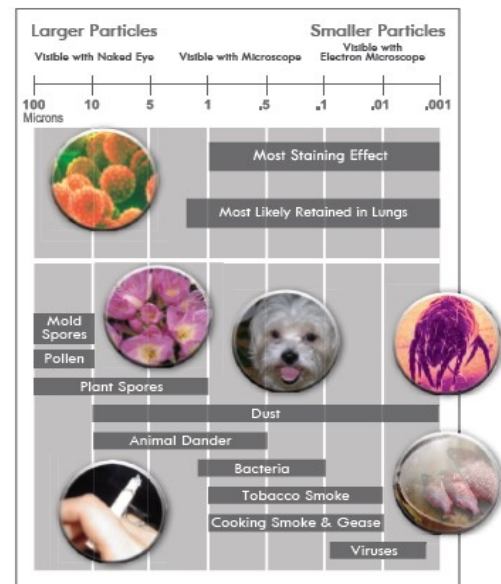

### Limited 5 Year Warranty



## SPECIFICATIONS

MODEL	EASA900VS	
<b>Air Flow: Variable Speed Motor Control</b>	Up to 250 cfm	Up to 425 m <sup>3</sup> /hr
<b>Carbon Prefilter: DM900-0855</b> Removes lint and large particles	Replace every 3-6 months	
<b>Long-Life, 99.97% HEPA Media: DMH4-0400</b> Removes pollutants 0.3 micron	40 ft <sup>2</sup> Replace every 2-4 years	3.7 m <sup>2</sup> Replace every 2-4 years
<b>Germicidal UVC Light: DM900-0191</b> Strongest light intensity kills bacteria, viruses, mold, fungi, allergens	2 Bulbs Replace every 13,000 hours or 2-3 years	
<b>CinQuartz<sup>®</sup> Substrate PCO Filter: DM900-0450</b> Removes Volatile Organic Compounds (VOC's)	Replace every 13,000 hours or 2-3 years	
<b>Carbon/ Potassium Permanganate Final Filter: DM900-0810</b> Removes VOC's and light gases	Replace every 1 year	
<b>Complete 2-3 Year Maintenance Kit: DM900-1003</b> Contains 1 HEPA Filter, 4 Carbon Prefilters, 2 UVC Lamps, 1 Photo Catalytic Oxidation (PCO) Filter, 2 Carbon/ Potassium Permanganate Final Filters, gloves	Replace every 2-3 years	
<b>Cabinet Dimensions: H x W x D</b>	29.5 x 16.25 x 12.75 in	74.9 x 41.3 x 32.4 cm
<b>Input Voltage</b>	120 V 60 hz	
<b>Power Consumption</b>	200 watts	
<b>Power Cord</b>	10.0 ft	3.05 m
<b>Unit Weight</b>	47 lbs	21.3 kg

### HOW IT WORKS

The air passes through a pleated Carbon Prefilter which removes lint and large particles to extend the life of the HEPA filter.

Smaller particles then pass through a long-life, 99.97% HEPA (High Efficiency Particulate Air) Media Filter which captures particles 0.3 micron (1/84,000 of an inch) and larger.

The clean air passes through a reflection chamber where two Ultraviolet Germicidal Lamps emit powerful UVC light rays which are designed to kill or inhibit bacteria, viruses, mold, fungus and microbial growth. These are non-ozone producing lamps. The Ultraviolet Lights are also used to activate the unique CinQuartz Media located below the UVC lamps.

The Photo Catalytic Oxidation (PCO) Filter is a Quartz media coated with nanoparticles of Titanium Dioxide (TiO<sub>2</sub>). The combined action of the UVC light and the TiO<sub>2</sub> decomposes organic materials into basic molecules such as H<sub>2</sub>O and CO<sub>2</sub> and reduces odors and VOC's as a result.

A Carbon/ Potassium Permanganate Final Filter further reduces VOC's and light gases.

Clean air is discharged.

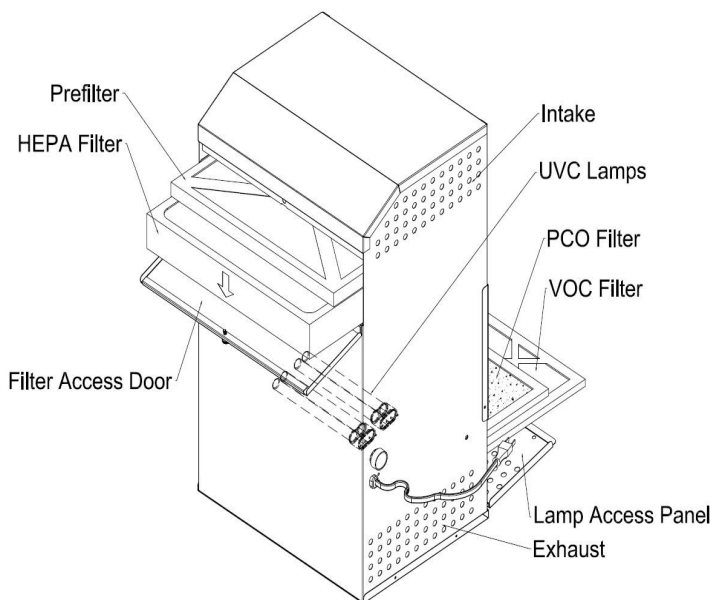

**ELECTRO-AIR CANADA**  
 351 North Rivermede Road, Concord, Ontario, Canada L4K 3N2  
 Tel: (416) 213-5636 Fax: (416) 213-5593  
 Toll Free: (800) 267-8305  
 info@fiveseasonsaircleaners.com www.fiveseasonsaircleaners.com



## DUCT OR WALL MOUNT HEPA AIR CLEANER WITH ULTRAVIOLET LIGHT & PHOTO CATALYTIC FILTER

### Description

- The 5-in-1 Clean Air Machine by Electro-Air offers the ultimate in air filtration and sterilization. This patented combination uses HEPA, UVC Germicidal Light (non ozone producing) and Photo Catalytic Oxidation. It removes and destroys allergens, lung damaging atmospheric dust, biological and chemical contaminants and odours, such as toluene, benzene, cooking odours, tobacco & cannabis smoke and odours, bacteria, viruses, mold and lots more.
- Ideal for residential and commercial applications where there are allergy/ respiratory sufferers, new construction odours, smokers, pets, mold, water & sewer damage, garbage disposal rooms, cannabis manufacturing processes and more.

### Standard Features

- Carbon Prefilter protects the HEPA filter while removing lint, hair and larger particles.
- Long-life, 99.97% HEPA Media Filter removes particles 0.3 micron (1/84,000 of an inch) and larger such as atmospheric and household dust, coal dust, insecticide dust, mites, pollen, mold spores, fungi, bacteria, viruses, pet dander, cooking smoke and grease, tobacco and cannabis smoke particles and more. The HEPA filter becomes more efficient as it becomes dirtier with time.
- Two UVC Germicidal Lights are enclosed in a Reflector which intensifies the UVC rays.
- Unique CinQuartz<sup>®</sup> Photo Catalytic Oxidation Filter (PCO) has a very high surface exchange capability and allows UV light into the mass of the material — means there is absorption throughout the whole CinQuartz filter instead of just on the surface. The combination of the UVC light and the CinQuartz<sup>®</sup> decomposes organic materials into basic molecules such as H<sub>2</sub>O and CO<sub>2</sub>.
- Carbon/ Potassium Permanganate Final Filter for removal of any trace Volatile Organic Compounds (VOC's) and light gases.
- Powerful European, energy efficient motor delivers up to 250 CFM of pure air, without adding static pressure to the HVAC system.
- Plug-in Power Cord provides convenient electrical connection.
- Versatile installation can be duct mounted, collar mounted or used as a stand alone unit. Stands available with or without wheels.



### Cabinet Construction Features

- One piece wrap, steel cabinet has powder-coat paint finish to provide rigid installation and durability.
- Pre-punched openings at back of unit and mounting template are provided for easier duct mount installation; no external ducting required.
- Pre-punched openings at top and bottom of unit facilitate collar mount installation.

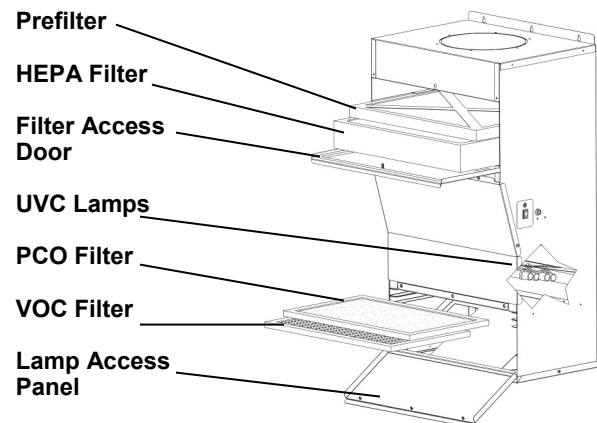

### Limited 5 Year Warranty



## SPECIFICATIONS

MODEL	EADM900UV-VO-VS	
<b>Air Flow: Variable Speed</b>	Up to 250 cfm	Up to 425 m <sup>3</sup> /hr
<b>Carbon Prefilter: DM900-0855</b> Removes lint and large particles	Replace every 3-6 months	
<b>Long-Life, 99.97% HEPA Media: DMH4-0400</b> Removes pollutants 0.3 micron	40 ft <sup>2</sup> Replace every 2-4 years	3.7 m <sup>2</sup> Replace every 2-4 years
<b>Germicidal UVC Light: DM900-0191</b> Strongest light intensity kills bacteria, viruses, mold, fungi, allergens	2 Bulbs Replace every 13,000 hours or 2-3 years	
<b>CinQuartz® Substrate PCO Filter: DM900-0450</b> Removes Volatile Organic Compounds (VOC's)	Replace every 13,000 hours or 2-3 years	
<b>Carbon/ Potassium Permanganate Final Filter: DM900-0810</b> Removes VOC's and light gases	Replace every 1 year	
<b>Complete 2-3 Year Maintenance Kit: DM900-1003</b> Contains 1 HEPA Filter, 4 Carbon Prefilters, 2 UVC Lamps, 1 Photo Catalytic Oxidation (PCO) Filter, 2 Carbon/ Potassium Permanganate Final Filters, gloves	Replace every 2-3 years	
<b>Cabinet Dimensions: H x W x D</b>	29.5 x 16.25 x 12.75 in	74.9 x 41.3 x 32.4 cm
<b>Intake Duct Fitting</b>	14.5 x 3.75 in or 8 in (dia)	36.8 x 9.5 cm or 20.3 cm (dia)
<b>Outflow Duct Fitting</b>	14.5 x 4.37 in or 8 in (dia)	36.8 x 11.1 cm or 20.3 cm (dia)
<b>Input Voltage</b>	120 v 60 hz	
<b>Power Consumption</b>	200 watts	
<b>Power Cord</b>	10.0 ft	3.05 m
<b>Unit Weight</b>	47 lbs	21.3 kg

## HOW IT WORKS

Millions of airborne pollutants are carried through the return air ducts of the heating/cooling system. The Air Cleaner has been designed to be installed on the return air duct. A portion of this return air is by-passed through an opening on the rear of the unit and passes through a 5-stage filtration system.

The air passes through a pleated Carbon Prefilter which removes lint and large particles to extend the life of the HEPA filter.

Smaller particles then pass through a long-life, 99.97% HEPA (High Efficiency Particulate Air) Media Filter which captures particles 0.3 micron (1/84,000 of an inch) and larger.

The clean air passes through a reflection chamber where two Ultraviolet Germicidal Lamps emit powerful UVC light rays which are designed to kill or inhibit bacteria, viruses, mold, fungus and microbial growth. These are non-ozone producing lamps. The Ultraviolet Lights are also used to activate the unique CinQuartz Media located below the UVC lamps.

The Photo Catalytic Oxidation (PCO) Filter is a Quartz media coated with nanoparticles of Titanium Dioxide (TiO<sub>2</sub>). The combined action of the UV light and the TiO<sub>2</sub> decomposes organic materials into basic molecules such as H<sub>2</sub>O and CO<sub>2</sub> and reduces odors and VOC's as a result.

A Carbon/ Potassium Permanganate Final Filter further reduces VOC's and light gases.

Clean air is discharged back into the return air duct.

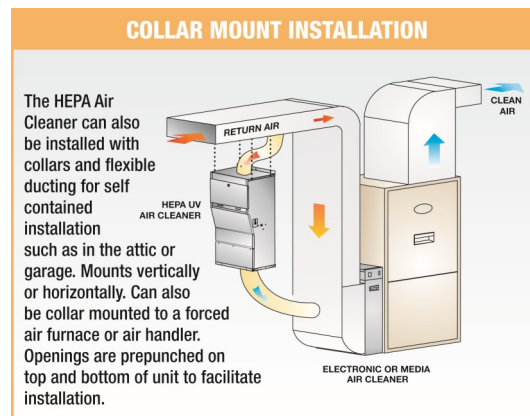
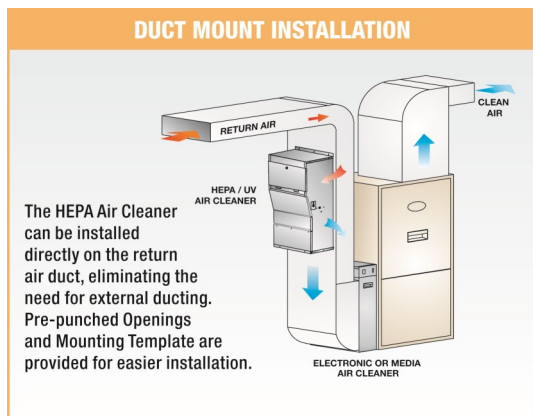

**ELECTRO-AIR CANADA**  
 351 North Rivermede Road, Concord, Ontario, Canada L4K 3N2  
 Tel: (416) 213-5636 Fax: (416) 213-5593  
 Toll Free: (800) 267-8305  
 info@fiveseasonsaircleaners.com www.fiveseasonsaircleaners.com





## 3-IN-1 DUCT OR WALL MOUNT HEPA AIR CLEANER

### Description

- The Electro-Air Duct or Wall Mount HEPA Air Cleaners have been designed to remove atmospheric and household dust, coal dust, insecticide dust, mites, pollen, mold spores, fungi, bacteria, viruses, pet dander, cooking smoke and grease, tobacco and wood smoke particles, and more down to 0.3 micron (1/84,000 of an inch) with 99.97% efficiency on the first pass of air.
- Ideal for classrooms, daycare centers, fitness studios, hair/nail/beauty salons, dental/medical clinics, condos, homes and more.
- This unit is compact and can be installed directly on the return air vent. It can also be mounted directly to the furnace and collar mounted to the return air duct to save space.
- Helps protect and prolong the operating efficiency of the heating and cooling equipment.
- Model EAHEPADM400-VSG is perfect for wall mounting as it has built-in Intake & Exhaust Grills.
- Easy to install. Easy to maintain.
- Does not produce toxins such as ozone, plasma, ionic clusters, hydroxyl radicals, peroxide radicals or Volatile Organic Compounds from plastics.

### Standard Features

- Highly Efficient MERV 11 Prefilter removes lint and hair before they enter HEPA filter.
- Activated Carbon Prefilter removes odors to extend the life of the HEPA filter.
- Long-life, 99.97% HEPA Media Filter removes particles 0.3 micron (1/84,000 of an inch) and larger. The HEPA filter becomes more efficient as it becomes dirtier with time.
- Variable Speed Motor Control delivers up to 320 CFM of pure air.
- Energy Efficient German Motor/ Blower combination uses backward curved AC motorized impeller, PSC type with external rotor (uses 1/3 the amperage of a traditional North American or offshore motor).
- Plug-in Power Cord provides convenient electrical connection. Standard 120 Volt, 60 Hz.
- Versatile installation can be duct mounted, collar mounted or wall mounted. Multi-positional.
- CSA / UL Approved.
- Limited 5 Year Parts Warranty.



### Cabinet Construction Features

- One piece wrap, steel cabinet has TGIF environmentally-friendly powder-coat paint finish to provide rigid installation and durability.
- Pre-punched openings at back of unit and mounting template are provided for easier duct mount installation; no external ducting required (Model EAHEPADM400-VS).
- Pre-punched openings at top and bottom of unit facilitate collar mount installation (Model EAHEPADM400-VS).

### Replacement Filters

PART NUMBER	DESCRIPTION	REPLACE EVERY
<b>DMH4-0400</b>	HEPA 99.97% Media Filter	2-3 years
<b>DMH4-0855</b>	Prefilter, MERV 11	3-6 months
<b>DMH4-0810</b>	Carbon Prefilter	3-6 months

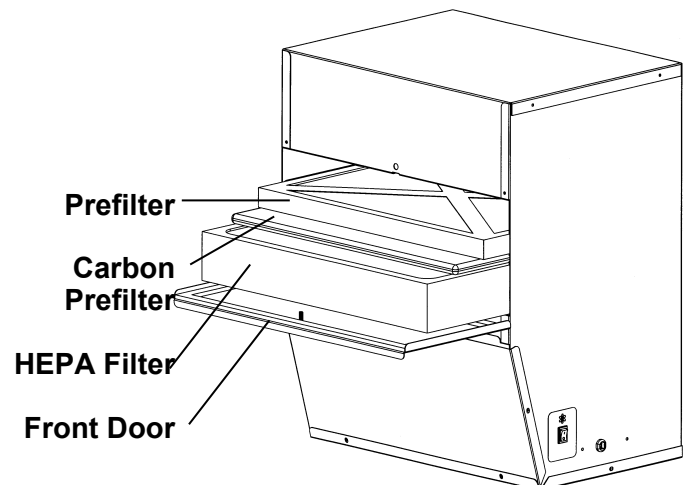

## SPECIFICATIONS

MODELS	EAHEPADM400-VS EAHEPADM400-VSG
<b>Air Flow: Variable Speed Motor Control</b>	Up to 320 cfm Up to 544 m <sup>3</sup> /hr
<b>Air Changes Per Day 1500 sq ft home 2000 sq ft home</b>	39 Air Changes / Day 29 Air Changes / Day
<b>Prefilter (MERV 11)</b>	3.1 ft <sup>2</sup> 0.29 m <sup>2</sup>
<b>Carbon Prefilter</b>	1.33 ft <sup>2</sup> 0.12 m <sup>2</sup>
<b>HEPA Media Filter</b>	40 ft <sup>2</sup> 3.7 m <sup>2</sup>
<b>Power</b>	120 V 60 hz
<b>Plug-in Power Cord</b>	10.0 ft 3.05 m
<b>Cabinet Dimensions WxDxH</b>	16.25 x 12.75 x 20.13 in 41.3 x 32.4 x 51.1 cm
<b>Intake Duct Fitting (EAHEPADM400-VS)</b>	14.5 x 3.75 in or 8 in (dia) 36.8 x 9.5 cm or 20.3 cm (dia)
<b>Outflow Duct Fitting (EAHEPADM400-VS)</b>	14.5 x 4.37 in or 8 in (dia) 36.8 x 11.1 cm or 20.3 cm (dia)
<b>Intake Grill Dimensions (EAHEPADM400-VSG)</b>	9.5 x 6.5 in 24.2 x 16.5 cm
<b>Outflow Grill Dimensions (EAHEPADM400-VSG)</b>	9.5 x 6.5 in 24.2 x 16.5 cm
<b>Unit Weight</b>	38 lbs 17.2 kg

### DUCT MOUNT INSTALLATION

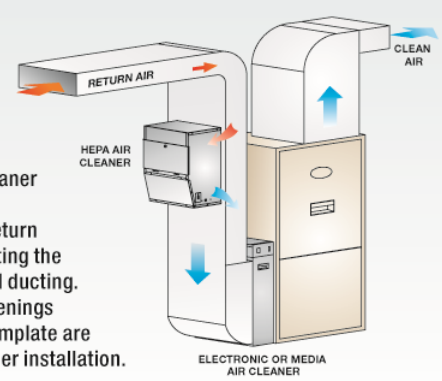

The HEPA Air Cleaner can be installed directly on the return air duct, eliminating the need for external ducting. Pre-punched Openings and Mounting Template are provided for easier installation.

### COLLAR MOUNT INSTALLATION

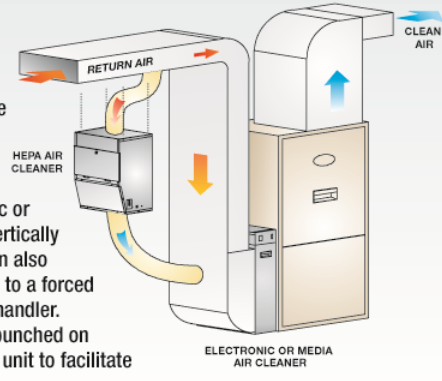

The HEPA Air Cleaner can also be installed with collars and flexible ducting for self contained installation such as in the attic or garage. Mounts vertically or horizontally. Can also be collar mounted to a forced air furnace or air handler. Openings are prepunched on top and bottom of unit to facilitate installation.

## HOW IT WORKS

Millions of airborne particulates and gases travel through the heating/cooling system 4-5 times every hour. The HEPA Air Cleaner connects to the return air duct and diverts 1/3 to 1/2 of this dirty air through a sealed 3-stage filtration system. A home can reach 39 or more whole-house air changes/day depending on the house size. And when an Electro-Air High Efficiency Electronic or Media Air Cleaner is added to the return air, the home can achieve 96+ whole-house air changes/day (with system fan on continuous).

Manufacturer reserves the right to discontinue or change at any time, specifications or designs without notice or without incurring obligations. Performance of the Air Cleaners will depend on house plan design, duct design and heating/cooling equipment.



**ELECTRO-AIR CANADA**  
 351 North Rivermede Road, Concord, Ontario, Canada L4K 3N2  
 Tel: (416) 213-5636 Fax: (416) 213-5593  
 Toll Free: (800) 267-8305  
[info@fiveseasonsaircleaners.com](mailto:info@fiveseasonsaircleaners.com) [www.fiveseasonsaircleaners.com](http://www.fiveseasonsaircleaners.com)



## WHOLE-HOUSE TRUE HEPA AIR CLEANERS

### Description

- The Electro-Air True HEPA Air Cleaner has been designed to remove 99.97% of atmospheric and household dust, coal dust, insecticide dust, mites, pollen, mold spores, fungi, bacteria, viruses, pet dander, cooking smoke and grease, tobacco & cannabis smoke particles, and more down to 0.3 micron (1/84,000 of an inch) on the first pass of air. As the HEPA filter becomes dirtier with time, it becomes more efficient and can capture particles as small as 0.001 micron.
- Ideal for homes with allergy, asthma or respiratory sufferers, smokers, pets, cooking odours and mustiness.
- Helps protect and prolong the operating efficiency of the heating and cooling equipment.

### Standard Features

- Long-life, Certified True HEPA (High Efficiency Particulate Air) Filter is a minimum 99.97% efficient at removing particles 0.3 micron in size.
- Activated Carbon Prefilter removes lint and unpleasant odors, to extend life of HEPA Filter.
- Carbon Volatile Organic Compound (VOC) After Filter removes additional unpleasant odors and gases (included with Model EAHEPA550-3).
- Carbon/Potassium Permanganate VOC Filter removes heavy duty odors and gases (optional upgrade for model EAHEPA550-3 only).
- Easy to change filters.
- Powerful European Motor delivers between 245 to 560 cfm of filtered air, depending on the model (with filters installed).
- Plug in Power Cord. No electrical wiring.
- Versatile installation can be freestanding, floor, ceiling or wall mounted.
- Limited 5 Year Warranty

### Cabinet Construction Features

- Heavy gauge steel cabinet and powder coat paint finish resist corrosion and provide rigid installation and durability.



### Replacement Filters

PART NO.	DESCRIPTION	REPLACE EVERY
<b>W6-0840</b>	Certified True HEPA Filter Cylinder for EAHEPA650	2-4 years
<b>W6-0855</b>	Carbon Prefilter Blanket for EAHEPA650	3-6 months
<b>W6-0810</b>	Inner Carbon VOC Blanket (optional) for EAHEPA650	3-6 months
<b>W5-0860-3</b>	True HEPA Filter 6" for EAHEPA550-3	3-5 years
<b>W5-0810</b>	Carbon Prefilter 1" for EAHEPA550-3	3-6 months
<b>W5-0820</b>	Carbon VOC After Filter 2" for EAHEPA550-3 (standard)	6-12 months
<b>W5-0885</b>	Carbon/Potassium Permanganate VOC After Filter 2" for EAHEPA550-3 (optional)	6-12 months
<b>W4-0840</b>	Certified True HEPA Filter Cylinder for EAHEPA450	2-4 years
<b>W4-0855</b>	Carbon Prefilter Blanket for EAHEPA450	3-6 months
<b>W4-0810</b>	Inner Carbon VOC Blanket for EAHEPA450 (optional)	3-6 months
<b>W3-0840</b>	Certified True HEPA Filter Cylinder for EAHEPA350	2-3 years
<b>W3-0855</b>	Carbon Prefilter Blanket for EAHEPA350	3-6 months
<b>W3-0810</b>	Inner Carbon VOC Blanket for EAHEPA350 (optional)	3-6 months

## SPECIFICATIONS

MODELS	EAHEPA350	EAHEPA450	EAHEPA550-3	EAHEPA650
<b>Air Flow: with all standard filters installed</b>	245 cfm 416.5 m <sup>3</sup> /hr	330 cfm 561 m <sup>3</sup> /hr	560 cfm 952 m <sup>3</sup> /hr	540 cfm 918 m <sup>3</sup> /hr
<b>Whole-House Air Changes/Day</b> 1500 ft <sup>2</sup> home 2500 ft <sup>2</sup> home	30 air changes/day 18 air changes/day	40 air changes/day 24 air changes/day	67 air changes/day 41 air changes/day	65 air changes/day 39 air changes/day
<b>Carbon VOC Prefilter</b>	2.45 ft <sup>2</sup> 0.23 m <sup>2</sup>	3.75 ft <sup>2</sup> 0.35 m <sup>2</sup>	6.3 ft <sup>2</sup> 0.585 m <sup>2</sup>	5.1 ft <sup>2</sup> 0.47 m <sup>2</sup>
<b>Certified True HEPA Filter</b>	65 ft <sup>2</sup> 6.04 m <sup>2</sup>	100 ft <sup>2</sup> 9.29 m <sup>2</sup>	188 ft <sup>2</sup> 17.47 m <sup>2</sup>	133 ft <sup>2</sup> 12.4 m <sup>2</sup>
<b>Carbon VOC After Filter</b>	See Options	See Options	9.5 ft <sup>2</sup> / 0.883 m <sup>2</sup>	See Options
<b>Power</b>	120 volt 60 hz 70 watts	120 volt 60 hz 125 watts	120 volt 60 hz 215 watts	120 volt 60 hz 215 watts
<b>Plug-In Power Cord</b>	10.0 ft 3.05 m	10.0 ft 3.05 m	10.0 ft 3.05 m	10.0 ft 3.05 m
<b>Cabinet Dimensions</b> <i>L x W x H</i>	18.25 x 18.25 x 19.25 in 46.4 x 46.4 x 48.9 cm	18 x 18 x 24.5 in 45.7 x 45.7 x 62.2 cm	21.5 x 20.5 x 28.4 in 54.5 x 52.0 x 72.0 cm	18 x 18 x 30.5 45.7 x 45.7 x 77.5 cm
<b>Intake Duct Fitting</b>	8 in 20.3 cm	8 in 20.3 cm	12 in 30.5 cm	12 in 30.5 cm
<b>Outflow Duct Fitting:</b> <b>Reversible</b>	6 in / 15.2 cm 1 Opening	6 in / 15.2 cm 2 Openings	8 in / 20.3 cm 2 Openings	8 in / 20.3 cm 2 Openings
<b>Unit Weight</b>	38 lbs (17.4 kg)	51 lbs (23.1 kg)	88 lbs (39.9 kg)	57 lbs (25.9 kg)
<b>Options Available</b>	Carbon VOC After Filter 1.39 ft <sup>2</sup> / 0.13 m <sup>2</sup>	Carbon VOC After Filter 2.13 ft <sup>2</sup> / 0.20 m <sup>2</sup>	Carbon/ Potassium Permanganate VOC After Filter for removal of noxious odors and gases 9.5 ft <sup>2</sup> / 0.883 m <sup>2</sup>	Carbon VOC After Filter 2.87 ft <sup>2</sup> / 0.27 m <sup>2</sup>

### HOW IT WORKS

Millions of airborne particulates and gases travel through the heating/cooling system 4-5 times every hour. The HEPA Air Cleaner connects to the return air duct and diverts 1/3 to 1/2 of this dirty air through a tightly sealed 3-stage filtration system. A home can reach as many as 67 whole-house air changes/day depending on the house size and model chosen. And when an Electro-Air High Efficiency Electronic or Media Air Cleaner is added to the return air, the home can achieve 96+ whole-house air changes/day (with system fan on continuous).

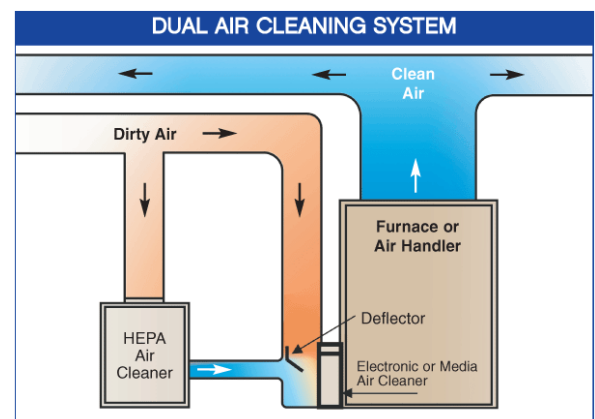

Manufacturer reserves the right to discontinue or change at any time, specifications or designs without notice or without incurring obligations. Performance of the Air Cleaners will depend on house plan design, duct design and heating/cooling equipment.



**ELECTRO-AIR CANADA**  
 351 North Rivermede Road, Concord, Ontario, Canada L4K 3N2  
 Tel: (416) 213-5636 Fax: (416) 213-5593  
 Toll Free: (800) 267-8305  
[info@fiveseasonsaircleaners.com](mailto:info@fiveseasonsaircleaners.com) [www.fiveseasonsaircleaners.com](http://www.fiveseasonsaircleaners.com)



## **PORTABLE TRUE HEPA AIR CLEANER ON WHEELS**

### **Description**

- The Electro-Air True HEPA Air Cleaner on Wheels has been designed to remove 99.97% of atmospheric and household dust, coal dust, insecticide dust, mites, pollen, mold spores, fungi, bacteria, viruses, pet dander, cooking smoke and grease, tobacco & cannabis smoke particles, and more down to 0.3 micron (1/84,000 of an inch) on the first pass of air. As the HEPA filter becomes dirtier with time, it becomes more efficient and can capture particles as small as 0.001 micron.
- Ideal for homes with allergy, asthma or respiratory sufferers, smokers, pets, cooking odors and mustiness.
- Ideal for light commercial use such as classrooms, daycare centers, dental clinics, doctor's offices, health and relaxation spas, offices, recreational studios, retirement homes and lots more.
- Easy to operate. Easy to change filters. Easy to maintain.
- Does not produce toxins such as ozone, plasma, ionic clusters, hydroxyl radicals, peroxide radicals or Volatile Organic Compounds from plastics.
- Cleans a room up to 763 ft<sup>2</sup> with 3 air changes per hour.



### **Standard Features**

- Long-life, Certified True HEPA (High Efficiency Particulate Air) Filter is a minimum 99.97% efficient at removing particles 0.3 micron in size.
- Activated Carbon Prefilter removes lint and unpleasant odors, to extend life of HEPA Filter.
- Carbon Volatile Organic Compound (VOC) After Filter removes additional unpleasant odors and gases.
- Intelligent Design intakes dirty air from left and right side intake grills and disperses pure air from back grill, never blowing air in room occupants' faces.
- Variable Speed Motor Control delivers up to 320 CFM of pure air.
- Energy Efficient German Motor/ Blower combination uses backward curved AC motorized impeller, PSC type with external rotor (uses 1/3 the amperage of a traditional North American or offshore motor).
- Plug in Power Cord. Standard 120 Volt, 60 Hz.
- Castors for easy maneuvering.
- Limited 5 Year Parts Warranty.
- CSA/UL Approved.
- Proudly Made in Canada.

### **Cabinet Construction Features**

- Heavy gauge steel cabinet and environmentally-friendly TGIF powder coat paint finish to resist corrosion.



## SPECIFICATIONS

MODEL	EAHEPA375VSC
<b>Air Flow: with all standard filters installed Variable Speed</b>	Up to 305 cfm Up to 518.5 m <sup>3</sup> /hr
<b>Recommended Room Size: Changes the air 3 times per hour in maximum room size. More in smaller rooms.</b>	Up to 763 ft <sup>2</sup>
<b>Carbon VOC Prefilter: W4-0855</b>	Replace every 3-6 months 3.75 ft <sup>2</sup> 0.35 m <sup>2</sup>
<b>Certified True HEPA Filter: W4-0840</b>	Replace every 4-5 years 100 ft <sup>2</sup> 9.29 m <sup>2</sup>
<b>Carbon VOC After Filter: W4-0810</b>	Replace every 12 months 2.13 ft <sup>2</sup> 0.20 m <sup>2</sup>
<b>Cabinet Dimensions L x W x H</b>	16.25 x 17.5 x 19 in 41.3 x 44.5 x 48.3 cm
<b>Intake Grills (2): Left &amp; Right Side W x H</b>	12.25 x 6 in 31.1 x 15.3 cm
<b>Exhaust Grill (1): Back of unit W x H</b>	12.25 x 6 in 31.1 x 15.3 cm
<b>Power</b>	120 volt 60 hz 75 watts
<b>Plug-In Power Cord</b>	10.0 ft 3.05 m
<b>Unit Weight</b>	43 lbs (19.5 kg)

Manufacturer reserves the right to discontinue or change at any time, specifications or designs without notice or without incurring obligations. Performance of the Air Cleaners will depend on house plan design, duct design and heating/cooling equipment.



**ELECTRO-AIR CANADA**  
 351 North Rivermede Road, Concord, Ontario, Canada L4K 3N2  
 Tel: (416) 213-5636 Fax: (416) 213-5593  
 Toll Free: (800) 267-8305  
[info@fiveseasonsaircleaners.com](mailto:info@fiveseasonsaircleaners.com) [www.fiveseasonsaircleaners.com](http://www.fiveseasonsaircleaners.com)



## **MOBILE TRUE HEPA AIR CLEANER & VOC FILTER**



### **Description**

- The Electro-Air Mobile True HEPA Air Cleaner & VOC Filter has been designed to remove 99.97% of atmospheric dust, coal dust, insecticide dust, mites, pollen, mold spores, fungi, bacteria, viruses, pet dander, cooking smoke and grease, tobacco & cannabis smoke particles, and more down to 0.3 micron (1/84,000 of an inch) on the first pass of air. As the HEPA filter becomes dirtier with time, it becomes more efficient and can capture particles as small as 0.001 micron.
- It also removes odours (with Carbon Prefilter and Carbon VOC After Filter) and heavy-duty odours and fumes (with optional Carbon/Potassium Permanganate VOC Filter).
- Ideal for commercial applications such as cafeterias, food preparation areas, garbage rooms, grow-ops, medical marijuana dispensaries, health care facilities, medical/ dental labs, nursing homes, Offices, print shops, locker rooms, and veterinary clinics.

### **Standard Features**

- Long-life, Certified True HEPA (High Efficiency Particulate Air) Filter is a minimum 99.97% efficient at removing particles 0.3 micron in size.
- Activated Carbon Prefilter removes lint and unpleasant odors, to extend life of HEPA Filter.
- Carbon VOC (Volatile Organic Compound) Filter removes additional unpleasant odours and gases (included with Model HEPA600M-3).
- Carbon/Potassium Permanganate VOC Filter (optional upgrade) removes heavy-duty odors and fumes such as formaldehyde, heptane, tetrachloroethylene, toluene, etc. that are off-gased from carpets, cabinets, furniture, paints, pesticides, personal care products, cleaners, etc.
- Powerful European Motor with two-speed fan delivers 360/600 CFM of pure air.
- Limited 5 Year Warranty.

- Large handle and swivel rubber castors for easy maneuvering.
- 10 foot power cord.

### **Cabinet Construction Features**

- Heavy gauge steel cabinet and powder coat paint finish for corrosion resistance and durability.
- Plastic intake and exhaust grills.

### **Replacement Filters**

<b>PART NO.</b>	<b>DESCRIPTION</b>	<b>REPLACE EVERY</b>
<b>W5-0860-3</b>	Certified True HEPA Filter 6"	3-5 years
<b>W5-0810</b>	Carbon Prefilter 1"	3-6 months
<b>W5-0820</b>	Carbon VOC After Filter 2" (standard)	6-12 months
<b>W5-0885</b>	Carbon/Potassium Permanganate VOC After Filter 2" (optional upgrade)	6-12 months

## SPECIFICATIONS

<b>Dimensions</b>	<b>Length</b> <b>Width</b> <b>Height (including casters)</b>	21.5 in 20.5 in 31.5 in	54.5 cm 52.0 cm 80.0 cm
<b>Unit Weight</b>		88.0 lbs	39.9 kg
<b>Input Voltage</b>		120 v 60 hz	
<b>Power Consumption</b>		215 watts	
<b>Air Flow</b>	<b>Low</b> <b>High</b>	360 cfm 600 cfm	601 m <sup>3</sup> /hr 1002 m <sup>3</sup> /hr
<b>Cabinet</b>		18 gauge	
<b>Power Cord</b>		10.0 ft	3.05 m
<b>Filter Dimensions</b>	<b>Carbon Prefilter</b> <b>HEPA Filter</b> <b>Carbon VOC Filter</b> <b>Carbon/Potassium VOC Filter</b>	19.5 x 19.5 x 1 in 19.5 x 19.5 x 6 in 19.5 x 19.5 x 2 in 19.5 x 19.5 x 2 in	49.5 x 49.5 x 2.5 cm 49.5 x 49.5 x 15.3 cm 49.5 x 49.5 x 5.0 cm 49.5 x 49.5 x 5.0 cm
<b>Carbon Prefilter Collecting Surface Area</b>		6.3 ft <sup>2</sup>	0.585 m <sup>2</sup>
<b>HEPA Collecting Surface Area</b>		188 ft <sup>2</sup>	17.5 m <sup>2</sup>
<b>VOC Filter Collecting Surface Area</b>		9.5 ft <sup>2</sup>	0.883 m <sup>2</sup>

### HOW IT WORKS

Air is drawn in through the top of the unit to the Activated Carbon Prefilter (1 inch pleated, activated carbon impregnated polyester filter) which removes lint and odours before they enter the HEPA filter.

Smaller particles then pass through a long-life, True HEPA (High Efficiency Particulate Air) Filter which captures 99.97% of particles 0.3 micron (1/84,000 of an inch) and larger. This 6 inch filter has more than 188 ft<sup>2</sup> of collection surface area.

Air is then drawn through a Carbon VOC (Volatile Organic Compound) Filter (2 inch) to remove unpleasant odours and gases, or an optional Carbon/Potassium Permanganate VOC Filter (2 inch) to remove noxious odours and fumes like formaldehyde, heptane, tetrachloroethylene, toluene, etc. that are off-gased from carpets, cabinets, furniture, paints, pesticides, personal care products, cleaners, etc.

Clean air is discharged from two sides of the unit.

Manufacturer reserves the right to discontinue or change at any time, specifications or designs without notice or without incurring obligations. Performance of the Air Cleaners will depend on house plan design, duct design and heating/cooling equipment.



**ELECTRO-AIR CANADA**  
351 North Rivermede Road, Concord, Ontario, Canada L4K 3N2  
Tel: (416) 213-5636 Fax: (416) 213-5593  
Toll Free: (800) 267-8305  
info@fiveseasonsaircleaners.com www.fiveseasonsaircleaners.com





## PORTABLE ELECTRONIC AIR CLEANER, NEGATIVE IONIZER & VOC FILTERS

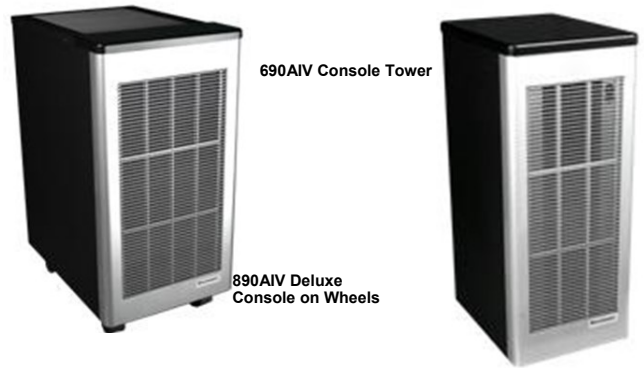

### Description

- The Portable Electronic Air Cleaners have been designed to remove atmospheric and household dust, coal dust, insecticide dust, mites, pollen, mold spores, fungi, bacteria, viruses, pet dander, cooking smoke and grease, tobacco smoke particles, and more down to 0.01 micron (0.01 micron = 1/2,540,000 of an inch).
- Contains an Environmentally-Friendly, Lifetime Filter System that simply washes clean.
- User-friendly controls.
- Easy to access filters and maintain.
- No costly filters to replace.

### Benefits

- Removes irritating airborne allergens. A must for allergy, asthma or respiratory sufferers.
- Helps reduce or eliminate offensive tobacco, cooking or pet odors.
- Helps reduce housekeeping time and redecorating costs by removing the black, greasy and staining airborne particles.
- Improves indoor air quality for a healthier, more comfortable environment, year-round.

### Standard Features

- Washable Prefilter captures large particles of dirt, lint and hair.

- Lifetime Electronic Filter charges pollutants by fine wires and attracts them to collecting plates, where they adhere like a magnet until washed away.
- Activated Carbon Odor & Gas (VOC) Filter helps remove Volatile Organic Compounds emitted from carpets, cabinetry, glues, household cleaners, paints, varnishes, solvents, personal care products, tobacco and cooking smoke, and more.
- Negative Ionizer adds healthy negative ions in the clean air stream to revitalize the air, just like after a rainfall, near a waterfall or spring. Studies link beneficial effects on human biochemistry, both physically and mentally.
- Performance Indicator Light shows air cleaner is operating properly at a glance.
- 3-Speed Fan Control.
- Cleans room every 20 minutes in recommended room size. More air changes/hour in smaller rooms.
- Limited 1 Year Warranty.

### Cabinet Construction Features

- Powder coat painted metal cabinet with minimal plastic trim, does not off-gas like other plastic type air cleaners or appliances.

### Options Available

- Available in 220 - 240 Volt, 50 - 60 Hz.

### Accessories

- DAX Air Cleaner Detergent simplifies the washing process by quickly and safely removing contaminants from filters.  
 32 oz. (1 L) Spray Bottle, Part #9900
- Activated Carbon Filters. Replace every 3-6 months.

## SPECIFICATIONS

### TABLETOP OR WALL-MOUNT

MODEL	490AIV	590AIV
<b>Ideal Room</b>	Bedroom, Family Room, Nursery, Office	Family or Living Room, Kitchen, Large Bedroom, Office
<b>Room Size</b>	240 ft <sup>2</sup> 22.3 m <sup>2</sup>	320 ft <sup>2</sup> 29.5 m <sup>2</sup>
<b>Air Changes</b>	3 Air Changes / Hour	3 Air Changes / Hour
<b>Air Flow Speeds</b>	50/80/100 cfm 85/136/178 m <sup>3</sup> /hr	60/80/130 cfm 102/136/221 m <sup>3</sup> /hr
<b>Dimensions</b>	18 x 12 x 5 inches 46 x 31 x 13 cm	20 x 12 x 5 inches 51 x 31 x 13 cm
<b>Weight</b>	13 lbs 5.9 kg	16 lbs 7.3 kg
<b>VOC Replacement</b>	49-0810	59-0810
<b>Negative Ionizer</b>	Dual	Dual

### CONSOLE TOWER

MODEL	680AIV	690AIV
<b>Ideal Room</b>	Family or Living Room, Kitchen, Large Bedroom, Office	Family or Living Room, Basement, Classroom, Condominium, Daycare Center, Doctor's Office, Waiting Room
<b>Room Size</b>	320 ft <sup>2</sup> 29.5 m <sup>2</sup>	612 ft <sup>2</sup> 57.0 m <sup>2</sup>
<b>Air Changes</b>	3 Air Changes / Hour	3 Air Changes / Hour
<b>Air Flow Speeds</b>	60/80/130 cfm 102/136/221 m <sup>3</sup> /hr	150/175/245 cfm 255/297/413 m <sup>3</sup> /hr
<b>Dimensions</b>	10 x 12 x 18 inches 26 x 31 x 46 cm	10 x 13.5 x 24.5 inches 25 x 34 x 62 cm
<b>Weight</b>	27 lbs 12.2 kg	32 lbs 14.5 kg
<b>VOC Replacement</b>	68-0810	69-0810
<b>Negative Ionizer</b>	Dual	Dual

### DELUXE CONSOLE ON WHEELS

MODEL	890AIV
<b>Ideal Room</b>	Large Living Area, Basement, Classroom, Condominium, Daycare Center, Doctor's Office, Waiting Room
<b>Room Size</b>	868 ft <sup>2</sup> 79.9 m <sup>2</sup>
<b>Air Changes</b>	3 Air Changes / Hour
<b>Air Flow Speeds</b>	170/245/350 cfm 289/416/595 m <sup>3</sup> /hr
<b>Dimensions</b>	13 x 19 x 26.5 inches 33 x 48 x 67 cm
<b>Weight</b>	42 lbs 19.1 kg
<b>VOC Replacement</b>	89-0810
<b>Negative Ionizer</b>	Dual



**ELECTRO-AIR CANADA**  
 351 North Rivermede Road, Concord, Ontario, Canada L4K 3N2  
 Tel: (416) 213-5636 Fax: (416) 213-5593  
 Toll Free: (800) 267-8305  
[info@fiveseasonsaircleaners.com](mailto:info@fiveseasonsaircleaners.com) [www.fiveseasonsaircleaners.com](http://www.fiveseasonsaircleaners.com)



## WHOLE-HOUSE HIGH EFFICIENCY ELECTRONIC AIR CLEANERS

### Description

- The Electro-Air High Efficiency Electronic Air Cleaner has been designed to remove atmospheric and household dust, coal dust, insecticide dust, mites, pollen, mold spores, fungi, bacteria, viruses, pet dander, cooking smoke and grease, tobacco smoke particles, and more down to 0.01 micron (0.01 micron = 1/2,540,000 of an inch).
- Contains an Environmentally-Friendly, Lifetime Filter System that never needs replacing. Simply washes clean.
- User-friendly. Easy to maintain.
- Ideal for homes with allergy, asthma or respiratory sufferers, smokers, pets, cooking odours, and mustiness.
- Helps protect and prolong the operating efficiency of the heating and cooling equipment.

### Standard Features

- Prefilters (2) are constructed of aluminum mesh, to prevent lint and large particles from entering the collecting cells.
- Dual Voltage Collecting Cells (2) are constructed of heavy gauge aluminum for durability and ease of maintenance. Cell guides ensure proper placement of collecting cells in cabinet.
- Activated Carbon Filters (C) help remove unpleasant odours.
- Solid State Power Board is manufactured on-site for high reliability and long life. Uniquely equipped with a variable resistor (potentiometer) to adjust high voltage output. Output has been preset for optimum efficiency, however, as voltage may vary in extreme conditions of dryness, humidity or proximity to hydro towers, raising or lowering potentiometer allows for proper voltage output.
- Electronic Air Proving Switch (AS) allows for quick wiring. Automatically cycles Air Cleaner on/off with the system fan.
- Lighted ON/OFF Switch (Orange) shows power to the Air Cleaner.



- Performance Indicator Light (Green LED) indicates high voltage to the collecting cells, ensuring air cleaner is operating properly at a glance.
- Limited 5 Year Warranty.

### Cabinet Construction Features

- Heavy gauge galvanized steel cabinet resists corrosion and provides trouble-free vertical or horizontal installation. Holes are provided to facilitate mounting to the duct work or air handling system.
- Durable powder coat paint finish on door and top lid resists corrosion.
- Power Box is removable. Contains the ON/OFF switch, performance indicator light, safety interlock switch, high voltage power board and the air proving switch.

### Accessories

- DAX Air Cleaner Detergent simplifies the washing process by quickly and safely removing contaminants from filters.  
32 oz. (1 L) Spray Bottle, Part #9900
- Activated Carbon Filters (3 per pack). Replace every 3-4 months. For models:  
EASASD-10ASC, EASASD-11ASC      Part #1156-3  
EASASD-12ASC, EASASD-18ASC      Part #1856-3

## EFFICIENCY

**ELECTRO-AIR ELECTRONIC AIR CLEANER**

Particle Size	600 CFM	1000 CFM	1400 CFM
0.3-0.4	99.2	87.5	65.4
0.4-0.55	99.7	91.6	74.0
0.55-0.7	99.8	95.1	80.3
0.7-1.0	99.9	97.3	86.0
1.0-1.3	99.9	98.5	90.4
1.3-1.6	99.9	99.1	93.2
1.6-2.2	100.0	99.5	95.3
2.2-3.0	100.0	99.8	97.4
3.0-4.0	100.0	99.9	98.3
4.0-5.5	100.0	99.9	99.0
5.5-7.0	100.0	100.0	99.5
7.0-10.0	100.0	100.0	99.9

**MEDIA**

1400 CFM Media (MERV 10)
14.6
21.2
30.9
38.6
46.9
53.9
61.8
74.6
82.6
84.5
86.4
88.2

In the chart to the left are results from an independent testing laboratory showing the efficiency of the Electro-Air Electronic Air Cleaner.

The column to the right shows the efficiency of a typical MERV 10 media filter (non Electro-Air).

At rated air flow the Electronic Air Cleaner achieves a MERV 14 rating. With the fan running on low speed the Air Cleaner increases efficiency to an impressive MERV 16 rating.

The static pressure drop of the Electrostatic Air Cleaner is a low 0.15" compared to a MERV 10 media filter of over 0.22" on a clean filter.

## SPECIFICATIONS

MODEL	EASASD-10ASC	EASASD-11ASC	EASASD-12ASC	EASASD-18ASC
<b>House Size Area</b>	<2400 ft <sup>2</sup> <222.96 m <sup>2</sup>	<3000 ft <sup>2</sup> <278.70 m <sup>2</sup>	<3000 ft <sup>2</sup> <278.70 m <sup>2</sup>	>3000 ft <sup>2</sup> >278.70 m <sup>2</sup>
<b>Airflow</b>	up to 1200 cfm up to 2039 m <sup>3</sup> /hr	up to 1400 cfm up to 2380 m <sup>3</sup> /hr	up to 1400 cfm up to 2380 m <sup>3</sup> /hr	up to 2000 cfm up to 3400 m <sup>3</sup> /hr
<b>Duct Size</b>	16 x 20 in 40.5 x 51 cm	16 x 25 in 40.5 x 63.5 cm	20 x 20 in 51.0 x 51.0 cm	20 x 25 in 51.0 x 63.5 cm
<b>Unit Weight</b>	33 lbs 15.3 kg	37 lbs 16.8 kg	37 lbs 16.8 kg	41 lbs 18.6 kg
<b>Input Voltage</b>	120 V 60 hz	120 V 60 hz	120 V 60 hz	120 V 60 hz
<b>Power Consumption</b>	30 watts	30 watts	30 watts	30 Wwatts
<b>Options Available</b>	Power Cord 220 v 50 hz	Power Cord 220 v 50 hz	Power Cord 220 v 50 hz	Power Cord 220 v 50 hz

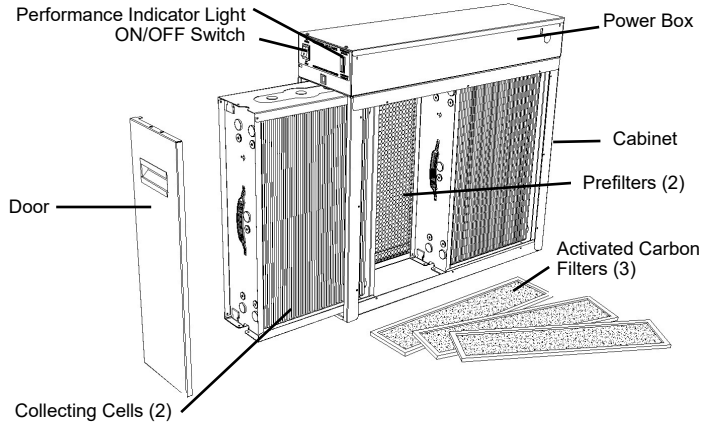
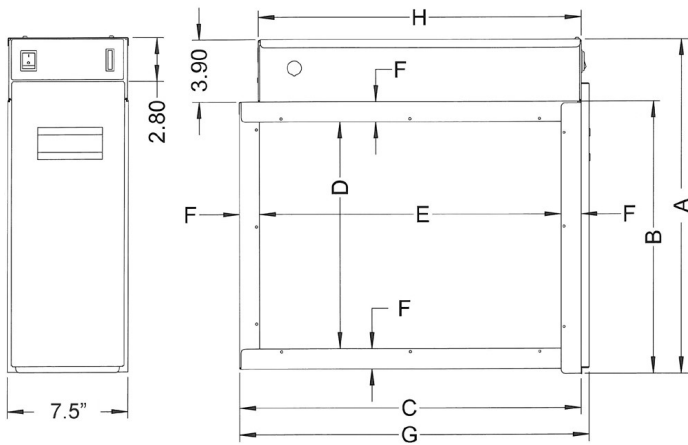

MODEL	DIMENSIONS — in (cm)							
	A	B	C	D	E	F	G	H
<b>EASASD-10ASC</b>	19.8 (50.4)	15.9 (40.5)	23.2 (58.9)	13.1 (33.3)	20.7 (52.5)	1.3 (3.2)	23.7 (60.2)	21.2 (53.9)
<b>EASASD-11ASC</b>	19.8 (50.4)	15.9 (40.5)	26.1 (66.3)	13.6 (34.6)	24.1 (61.2)	1.0 (2.5)	26.6 (67.7)	25.8 (65.4)
<b>EASASD-12ASC</b>	24.7 (62.8)	20.8 (52.9)	21.2 (53.9)	18.0 (45.7)	18.7 (47.5)	1.3 (3.2)	21.7 (55.2)	21.2 (53.9)
<b>EASASD-18ASC</b>	24.7 (62.8)	20.8 (52.9)	25.8 (65.4)	18.0 (45.7)	23.3 (59.1)	1.3 (3.2)	26.3 (66.8)	25.8 (65.4)

Manufacturer reserves the right to discontinue or change at any time, specifications or designs without notice or without incurring obligations. Performance of the Air Cleaners will depend on house plan design, duct design and heating/cooling equipment.



**ELECTRO-AIR CANADA**  
 351 North Rivermede Road, Concord, Ontario, Canada L4K 3N2  
 Tel: (416) 213-5636 Fax: (416) 213-5593  
 Toll Free: (800) 267-8305



info@fiveseasonsaircleaners.com      www.fiveseasonsaircleaners.com

## **HIGH EFFICIENCY RETURN GRILLE MOUNT ELECTRONIC AIR CLEANER**



### **Description**

- The Return Grille Mount Electronic Air Cleaner has been designed to remove atmospheric and household dust, coal dust, insecticide dust, mites, pollen, mold spores, fungi, bacteria, viruses, pet dander, cooking smoke and grease, tobacco smoke particles, and more down to 0.01 micron (0.01 micron = 1/2,540,000 of an inch).
- Contains an Environmentally-Friendly, Lifetime Filter System that never needs replacing. Simply washes clean.
- Designed for homes, condominiums, manufactured homes and applications where there is a common return grille rather than separate return air ducts from each room. Larger homes with more than one return grille may require an additional return grille air cleaner to greatly improve indoor air quality.
- Perfect for homes with attic or crawl space heating and air conditioning installations, allowing easy access to filters on the main floor.
- Easily installs on the wall or ceiling in a ceiling box within trusses on 24 inch centers, without any structural changes.
- Ideal for homes with allergy, asthma or respiratory sufferers, smokers, pets, cooking smoke, and mustiness.
- Helps protect and prolong the operating efficiency of the heating and cooling equipment.

### **Standard Features**

- Prefilters (2) are constructed of aluminum mesh, to prevent lint and large particles from entering the collecting cells.
- Collecting Cells (2) are constructed of heavy gauge aluminum for durability and ease of maintenance.
- Plastic Intake Grille is easy to wipe clean.

### **Standard Features**

- Hinged, Swing Out Door allows easy access to filters.
- Automatic Interlock Switch disconnects power when unit is opened.
- Electronic Air Proving Switch (AS) allows for quick wiring. Automatically cycles Air Cleaner on/off with the system fan.
- Performance Indicator Light (Green LED) indicates high voltage to the collecting cells, ensuring air cleaner is operating properly at a glance.
- Solid State Power Board is manufactured on-site for high reliability and long life. Uniquely equipped with a variable resistor (potentiometer) to adjust high voltage output, if necessary.
- Limited 5 Year Warranty.

### **Cabinet Construction Features**

- Durable powder coat paint finish on heavy gauge steel resists abrasion and provides trouble-free wall or ceiling installation. Holes are provided to facilitate mounting to the duct work.

### **Accessories**

- DAX Air Cleaner Detergent simplifies the washing process by quickly and safely removing contaminants from filters.  
32 oz. (1 L) Spray Bottle, Part #9900

## SPECIFICATIONS

MODEL	EAGM20AS-A
House Size	n/a
Air Flow	up to 2000 cfm up to 3398 m <sup>3</sup> /hr
Duct Size	22 x 29.1 in 55.9 x 73.9 cm
Cabinet Dimensions	31.4 x 24.4 x 7 in 79.8 x 62 x 17.8 cm
Weight	38 lbs 17.5 kg
Power	120 v 60 hz 30 watts

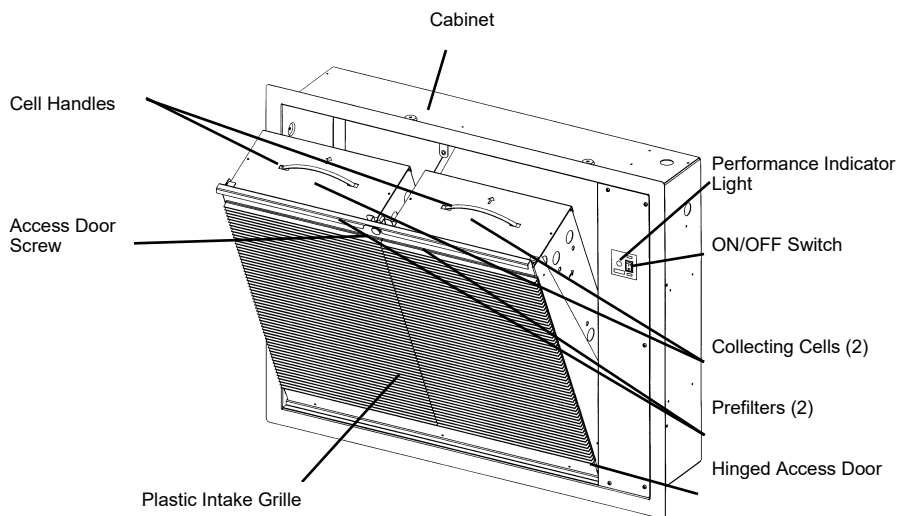

## DIMENSIONS

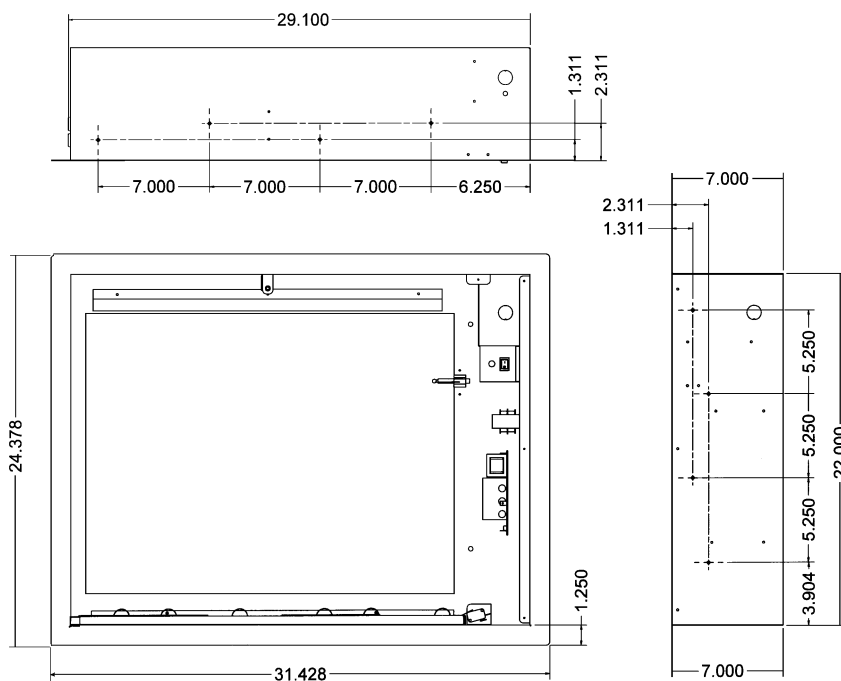

Manufacturer reserves the right to discontinue or change at any time, specifications or designs without notice or without incurring obligations. Performance of the Air Cleaners will depend on house plan design, duct design and heating/cooling equipment.



**ELECTRO-AIR CANADA**  
 351 North Rivermede Road, Concord, Ontario, Canada L4K 3N2  
 Tel: (416) 213-5636 Fax: (416) 213-5593  
 Toll Free: (800) 267-8305  
[info@fiveseasonsaircleaners.com](mailto:info@fiveseasonsaircleaners.com) [www.fiveseasonsaircleaners.com](http://www.fiveseasonsaircleaners.com)



## COMMERCIAL CEILING MOUNT ELECTRONIC AIR CLEANERS



**SSCB15W-R**



**SSCB7W-R**

### Description

- The Ceiling Mount Electronic Air Cleaners have been designed to remove tobacco, cigar and cannabis particles, cooking smoke and grease, atmospheric and insecticide dust, mites, pollen, mold spores, fungi, bacteria, viruses, dander and more, down to 0.01 micron (0.01 micron = 1/2,540,000 of an inch).
- Ideal for commercial environments including smoking rooms, cigar and cannabis lounges, hookah lounges, cafeterias, social clubs, legions, bingo halls, bars, taverns, restaurants, conference rooms, open concept offices, retail stores and more.
- Contains an Environmentally-Friendly, Lifetime Filter System that doesn't need replacing—simply washes clean.
- Easily installs on solid or T-bar ceiling.
- Contemporary styling fits in with almost any decor.
- Easy to operate and maintain.

### Benefits

- Provides a cleaner, healthier environment where everyone can relax or work together.
- Removes contaminants at the source, keeping HVAC ventilation system cleaner, extending maintenance time and longer life of equipment.
- Lowers energy bills by recycling rather than exhausting expensive heated/cooled air.
- Reduces housekeeping and redecorating costs by keeping the black and greasy particles off walls, furnishings, window coverings, light fixtures, fans, decor and more.
- Increases employee productivity and morale, by helping to eliminate irritated eyes, nasal congestion and respiratory problems that lead to absenteeism.

### Standard Features

- Prefilters are constructed of aluminum mesh, to prevent lint and large particles from entering the collecting cells.
- Collecting Cells are constructed of heavy gauge aluminum for durability and ease of maintenance.
- Intake Grille is removable and easy to wash clean.
- Coanda Air Flow pattern intakes dirty air through bottom grille and disperses clean air in four directions.
- 3-Speed Fan Control.
- Includes Remote Wall Control.
- Hinged, Swing Out Door allows easy access to filters.
- Automatic Interlock Switch disconnects power when unit is opened.
- Performance Indicator Light (Green LED) indicates high voltage to the collecting cells, ensuring air cleaner is operating properly at a glance.
- Limited 1 Year Warranty.

### Cabinet Construction Features

- Durable powder coat paint finish on heavy gauge steel resists abrasion and provides trouble-free installation. Mounting holes provided. Choice of off-white (W) or dark grey (G). Custom colors available upon request.

### Options Available

- Available in 220 - 240 Volt, 50 - 60 Hz.

### Accessories

- DAX Air Cleaner Detergent simplifies the washing process by quickly and safely removing contaminants from filters.  
 32 oz. (1 L) Spray Bottle, Part #9900  
 1 gallon (4.4 L) Jug, Part #9902

## SPECIFICATIONS

### CEILING MOUNT ELECTRONIC AIR CLEANER SSCB15W-R (Off White), SSCB15G-R (Dark Grey)

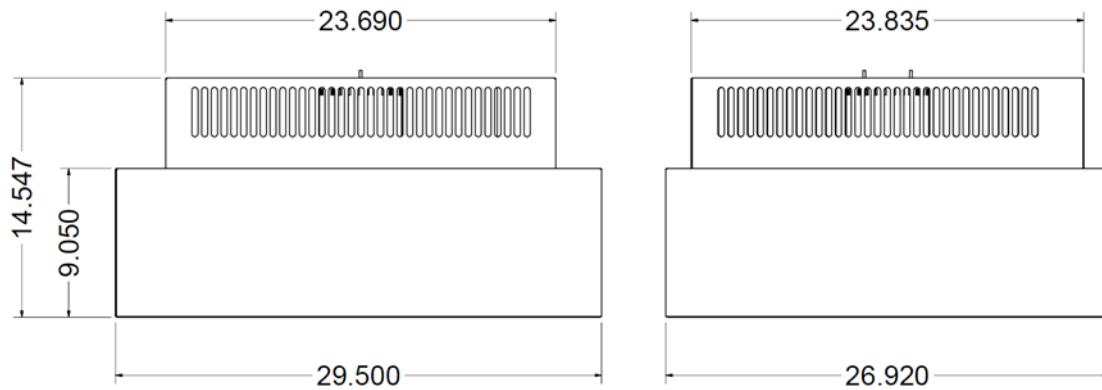

<b>Unit Weight</b>	95 lbs	43 kg
<b>Input Voltage</b>	120 volt / 60 hz	
<b>Power Consumption</b>	3.5 amps	
<b>Air Flow</b>		
Low	750 cfm	1275 m <sup>3</sup> /hr
Medium	1050 cfm	1785 m <sup>3</sup> /hr
High	1300 cfm	2210 m <sup>3</sup> /hr
<b>Motor</b>	1/12 hp	
<b>Options Available</b>	220-240 volt / 50-60 hz	

### SEMI-FLUSH CEILING MOUNT ELECTRONIC AIR CLEANER SSCB7W-R (Off White), SSCB7G-R (Dark Grey)

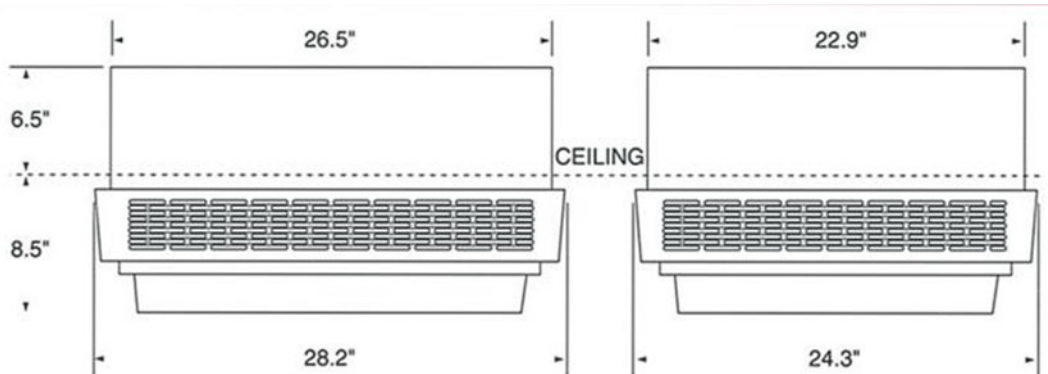

<b>Unit Weight</b>	70 lbs	32 kg
<b>Input Voltage</b>	120 volt / 60 hz	
<b>Power Consumption</b>	1.5 amps	
<b>Air Flow</b>		
Low	440 cfm	748 m <sup>3</sup> /hr
Medium	575 cfm	977 m <sup>3</sup> /hr
High	712 cfm	1210 m <sup>3</sup> /hr
<b>Motor</b>	1/3 hp	
<b>Options Available</b>	220-240 volt / 50-60 hz	



## COMMERCIAL / INDUSTRIAL SELF-CONTAINED ELECTRONIC AIR CLEANER

### Description

- The Self-Contained Electronic Air Cleaner can be installed for general ventilation or ducted for source capture. Electronically removes a wide range of harmful airborne pollutants as small as 0.01 micron (0.01 micron = 1/2,540,000 of an inch), such as welding fumes, oil mist, dust, tobacco and cannabis smoke, and lots more.
- Contains an Environmentally-Friendly, Filter System that simply washes clean with DAX Air Cleaner Detergent.
- Manufactured under strict quality control standards to deliver high performance and reliable operation.
- Improves indoor air quality for a healthier, more efficient and profitable environment.

### Benefits

- Dramatically Lowers Energy Costs by recycling rather than exhausting expensive heated/cooled air.
- Reduces Absenteeism and Turnover by providing a healthier, safer environment for the process operator and surrounding work force. Also protects office personnel from drifting, irritating pollutants.
- Increases Productivity and Accuracy resulting from a more comfortable breathing zone and higher morale.
- Prevents Contaminant Build-Up On Equipment Surfaces and Finished Products so there is far less time and energy spent on cleaning and re-work.
- Helps Meet Indoor Air Quality Requirements to avoid costly penalties.

### Features

- Prefilters: Washable, multi-layered aluminum mesh prevents large pollutants from entering collector cell. Contains (2).
- Ionizer: Rust-resistant satin coat steel frame with 10 Tungsten wires creates a high density electrical field to charge pollutants down to 0.01 micron. Contains (2).
- Collector Cell: Captures welding fumes, oil mist, dust, smoke and other pollutants down to 0.01 micron. Washable, corrosion-resistant aluminum collector cell has surface area of 62.8 ft<sup>2</sup> (5.83 m<sup>2</sup>). Contains (2).



- After Filter: Washable, multi-layered aluminum mesh filter collects agglomerated dust, maintains back pressure and keeps efficiency constant. Contains (2).
- Clean Air Discharge: 4-way adjustable air outlet louver.
- Filter and Blower Access: Fan housing and motor compartment have two access doors for easy servicing. A separate door activates the safety interlock that services the collector cells and ionizing section. Gaskets prevent air leakage.
- Control Panel: ON/OFF Lighted Rocker Switch controls voltage to collector cells. Fan ON/OFF Lighted Rocker Switch allows easy drying of collector cells after washing. Performance Indicator Light shows collector cells are operating properly at a glance.
- Electrical Cabinet: Removable. Protects electronics from contaminant build-up. Unique, solid-state power supply is field adjustable for increased efficiency.

### Cabinet Construction Features

- 18 gauge steel with a powder-coat paint finish resists wear and tear.
- Includes 4 - 1/2" in U.N.C. captive weld nuts.

### Options Available

- Flex-Adapter
- Hi-Velocity Intake Hood
- Activated Carbon VOC Filters removes noxious odours and gases, including tobacco and cannabis odours.

## SPECIFICATIONS

MODEL	EASC924-1
<b>Air Capacity</b>	2,100 cfm (3,570 m <sup>3</sup> /hr)
<b>Power Consumption</b>	120 v 60 hz 1 phase 11.5 A
<b>Motor</b>	3/4 HP TEFC, ball bearings with thermal protection. 120 v 60 hz 1 phase 10.8 A (Other voltages are optional.)
<b>Overall Dimensions <i>W x L x H</i></b>	34.0 x 46.0 x 27.0 in (86.4 x 116.8 x 68.6 cm)
<b>Weight</b>	275.0 lbs (124.7 kg)
<b>Shipping Weight</b>	325.0 lbs (147.4 kg)
<b>Cleaning Solution</b>	DAX DETERGENT Available in 4.4 gal (20 l), 45 gal (204.6 l) drum containers. Heavy duty cleaner expressly for removal of accumulated pollutants on collector cell plates.

## HOW IT WORKS

The EASC924-1 Self-Contained Electronic Air Cleaner operates on the principle of electrostatic precipitation. Millions of airborne pollutants are drawn in through the intake grill on the front of the air cleaner and first pass through the prefilters where large particles are caught. Next, smaller particles move to the two-stage electrostatic collecting cells where they are given a powerful positive charge by the ionizing wires. Charged particles then move into the collecting area where they are attracted to a series of alternately charged and grounded plates. Pollutants are held on the plates like a magnet until washed away during cleaning. Air passes through the after filters to collect any agglomerated dust or through the optional carbon VOC filters to remove odours and gases, and is then dispersed through the exhaust grill.

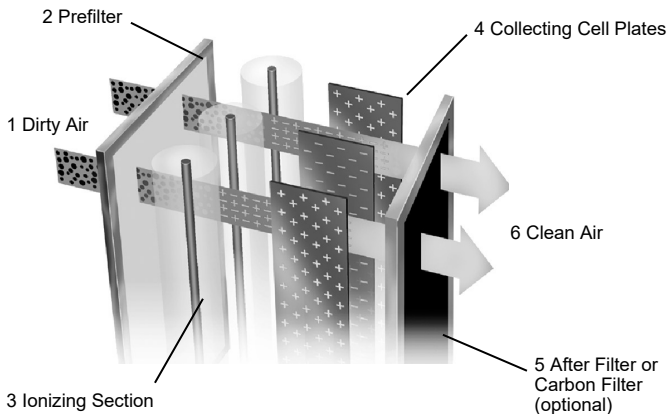

### Electrostatic Precipitation

## TYPICAL APPLICATIONS

- |  |   |
|--|---|
| <ul style="list-style-type: none"> <li>Brazing</li> <li>Cannabis Grow-ops</li> <li>Cold Forming</li> <li>Gear Cutting</li> <li>Heat Treating</li> <li>Induction Heating</li> <li>Machining</li> <li>Milling</li> <li>Plasma Cutting</li> </ul> | <ul style="list-style-type: none"> <li>Plastic and Rubber Forming</li> <li>Quenching</li> <li>Rubber Grinding</li> <li>Soldering</li> <li>Threading</li> <li>Warehouses</li> <li>Welding</li> <li>Wet Grinding</li> <li>Wire Drawing</li> </ul> |
|--|---|

Manufacturer reserves the right to discontinue or change at any time, specifications or designs without notice or without incurring obligations.



**ELECTRO-AIR CANADA**  
 351 North Rivermede Road, Concord, Ontario, Canada L4K 3N2  
 Tel: (416) 213-5636 Fax: (416) 213-5593  
 Toll Free: (800) 267-8305  
[info@fiveseasonsaircleaners.com](mailto:info@fiveseasonsaircleaners.com)    [www.fiveseasonsaircleaners.com](http://www.fiveseasonsaircleaners.com)



## **MOBILE PARTICULATE REMOVAL SYSTEM ELECTRONIC AIR CLEANER**

### **Description**

- The Mobile Electronic Air Cleaner can be used anywhere on the shop floor. Captures a wide range of harmful airborne pollutants as small as 0.01 micron (0.01 micron = 1/2,540,000 of an inch), such as welding fumes, oil mist, dust and lots more.
- Powerful source capture zone works directly at the point of maximum concentration, up to 20 inches (50.8 cm) away.
- Contains an Environmentally-Friendly, Lifetime Filter System that simply washes clean.
- Delivers high performance, quiet operation and easy handling. Easy to maintain.

### **Benefits**

- Lowers Energy Costs by recycling rather than exhausting expensive heated/cooled air.
- Reduces Absenteeism and Turnover by providing a healthier, safer environment for the process operator and surrounding work force.
- Increases Productivity and Accuracy resulting from a more comfortable breathing zone.
- Prevents Contaminant Build-Up on Finished Products so there is less time and energy spent on cleaning and re-work.
- Improves Indoor Air Quality for a healthier, more efficient and profitable work environment.

### **Features**

- **Source Capture Arm:** Self-supporting frame inside the flex duct allows for clean looks and easy maneuverability. Four (4) adjustable friction lock joints secure arm in desired position. Industrial grade, urethane, chemical resistant, high temperature flexible duct. Arm has 7.0 ft (2.1 m) reach, 360° swing, 8 in (20.3 cm) diameter. Capture nozzle is cone shaped with a capture zone of 12-20 in (30.5-50.8 cm).
- **Pre-filter:** Washable, multi-layered aluminum mesh prevents large pollutants from entering collector cell.
- **Ionizer:** Rust-resistant satin coat steel frame with ten (10) Tungsten wires.
- **Collector Cell:** Captures welding fumes, oil mist, dust and other pollutants down to 0.01 micron. Washable, corrosion-resistant aluminum cell has surface area of 62.8 ft<sup>2</sup> (5.83 m<sup>2</sup>).



- **After Filter:** Washable, multi-layered aluminum mesh filter collects agglomerated dust, maintains back pressure and keeps efficiency constant.
- **Clean Air Discharge:** Located above the breathing zone of process operator.
- **Motor & Blower:** Two AC motorized centrifugal impellers are utilized to draw air evenly across the face of the cell. The single inlet blower wheels are backward curved, measuring 9 in. diameter by 4 in. wide (22.9 x 10.2 cm). The energy efficient, ball bearing fan motors draw only 185 watts each.

- **Control Panel:** ON/OFF Lighted Rocker Switch controls voltage to collector cell. Fan ON/OFF Lighted Rocker Switch allows easy drying of collector cell after washing. Performance Indicator Light shows collector cell is operating properly at a glance.
- **Electrical Cabinet:** Protects electronics from contaminant build-up. Removable. Unique, solid-state power supply is field adjustable for increased efficiency.

### **Cabinet Construction Features**

- Heavy gauge steel with powder-coat paint finish resists wear and tear. Mounted on 4 heavy-duty swivel locking casters.
- Interlocked Access Door allows entry to ionizer, cell and filters.

### **Options Available**

- 10 ft (3.05) Source Capture Arm comes with outriggers, 360° swing, 8 in (20.3 cm) diameter.
- High Speed Capture Nozzle.
- Activated Carbon Filter removes noxious odours and gases.

## SPECIFICATIONS

MODEL	EAMPRS1000
<b>Air Capacity</b>	1000 cfm (1700 m <sup>3</sup> /hr)
<b>Rated Capture Velocity</b>	1100 fpm (225.3 m/min)
<b>Power Consumption</b>	120 v 60 hz 1 phase 3.6 A
<b>Motor</b>	Contains (2) Energy Efficient, High End European Motors 120 v 60 hz 1 phase 1.5 A
<b>Power Cord</b>	10.0 ft (3.05 m) with 3-prong plug
<b>Overall Dimensions <i>L x W x H</i></b>	28.0 x 18.0 x 36.0 in (71.0 x 45.7 x 91.5 cm)
<b>Weight</b>	281.0 lbs (127.5 kg)
<b>Shipping Weight</b>	310.0 lbs (141.0 kg)
<b>Cleaning Solution</b>	DAX Detergent—Available in 4.4 gal (20 l), 45 gal (204.6 l) drum containers. Heavy duty cleaner expressly for removal of accumulated pollutants on collector cell plates.

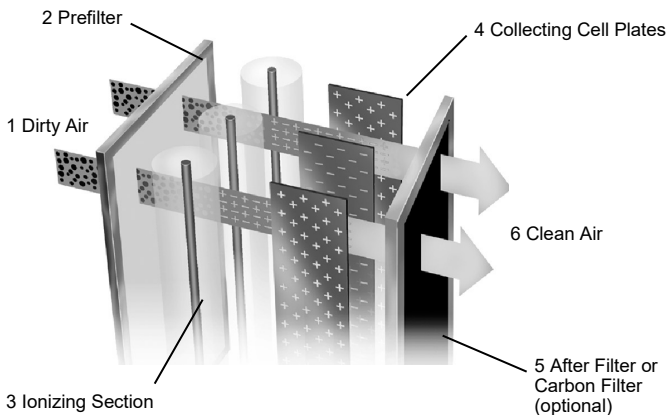

**Electrostatic Precipitation**

### HOW IT WORKS

The EAMPRS1000 Mobile Particulate Removal System operates on the principle of electrostatic precipitation. Airborne pollutants are drawn in through the direct capture arm and first pass through to the prefilter, where large particles are caught. Next, smaller particles move to a two-stage electrostatic collector cell where they are given a powerful positive charge by the ionizing wires. Charged particles then move into the collecting area where they are attracted to a series of alternately charged and grounded plates. Pollutants are held on the plates like a magnet until washed away during cleaning. Air passes through the after filter to collect any agglomerated dust and is then dispersed from the top of the unit.

## TYPICAL APPLICATIONS

- |  |  |
|--|--|
| <ul style="list-style-type: none"> <li>Brazing</li> <li>Cold Forming</li> <li>Gear Cutting</li> <li>Heating Treating</li> <li>Induction Heating</li> <li>Machining</li> <li>Milling</li> <li>Plasma Cutting</li> </ul> | <ul style="list-style-type: none"> <li>Plastic and Rubber Forming</li> <li>Quenching</li> <li>Soldering</li> <li>Threading</li> <li>Welding</li> <li>Wet Grinding</li> <li>Wire Drawing</li> </ul> |
|--|--|

Manufacturer reserves the right to discontinue or change at any time, specifications or designs without notice or without incurring obligations.



**ELECTRO-AIR CANADA**  
 351 North Rivermede Road, Concord, Ontario, Canada L4K 3N2  
 Tel: (416) 213-5636 Fax: (416) 213-5593  
 Toll Free: (800) 267-8305  
[info@fiveseasonsaircleaners.com](mailto:info@fiveseasonsaircleaners.com) [www.fiveseasonsaircleaners.com](http://www.fiveseasonsaircleaners.com)



## WHOLE-HOUSE HIGH EFFICIENCY MEDIA RETROFIT AIR CLEANERS

### Description

- The Electro-Air High Efficiency Charged-Media Retrofit Air Cleaner has been designed to remove atmospheric and household dust, coal dust, insecticide dust, mites, pollen, mold spores, fungi, bacteria, pet dander, cooking smoke and grease, tobacco smoke particles, and more down to 0.3 micron (1/84,000 of an inch).
- Ideal for homes with allergy, asthma or respiratory sufferers, smokers, pets and mustiness.
- Helps protect and prolong the operating efficiency of the heating and cooling equipment.

### Standard Features

- High Efficiency MERV\* 11 Media Filter, rated at 492 feet/minute, removes airborne contaminants down to 0.3 micron.
- Filter material is constructed of continuous hydrophobic polyolefin fibers that will not shred or absorb moisture. They are cellulose free and will not sustain mold growth.
- Unique filter design features a structured density gradient with an electret charge for higher initial and sustained efficiency over the life of the filter.
- Extra deep, 5¼ inch filter, contains more media material than other filters on the market. More surface area means more collection area, longer filter life and lower static pressure.
- Perfect fit filter has an exact fit with the cabinet. Does not contain foam, sponge or fiberglass filler. Means all the air is passing through the filter and not through filler material, thereby maximizing the system's ability to clean the air.
- User-friendly, easy-to-change filter cartridge means no fussing with complicated combs or brackets.
- Filter lasts up to one year in standard applications.
- Reversible air flow. Mounts in any position.
- Easily upgrades to an Electro-Air High Efficiency Electronic Air Cleaner, which is capable of removing harmful contaminants as small as 0.01 micron (1/2,540,000 of an inch).
- Limited 5 Year Warranty.



### Cabinet Construction Features

- Heavy gauge galvanized steel cabinet resists corrosion and provides trouble-free vertical or horizontal installation. Holes are provided to facilitate mounting to the duct work or air handling system.
- Durable powder coat paint finish on door resists corrosion.

### Media Replacement Filters

- Replacement filters are packaged 3 per box. Replace 1 to 2 times per year depending on climate, home renovations, smoking in home, or number of pets. For Models:  
EAMU1620-A replace with #M0-1056 (MERV 11)  
EAMU1625-A replace with #M1-1056 (MERV 11) or G1-1056 (MERV 14) upgrade  
EAMU2020-A replace with #M2-1056 (MERV 11)  
EAMU2025-A replace with #M8-1056 (MERV 11) or G8-1056 (MERV 14) upgrade

### Accessories

- Activated Carbon Filters (3 per pack) help eliminate unpleasant odours. Replace every 3-6 months. For models:  
EAMU1620-A/ EAMU1625-A Part #1156-3  
EAMU2020-A/ EAMU2025-A Part #1856-3
- Upgrade Kit to Electronic Air Cleaner includes Prefilters (2), Collecting Cells (2), Power Box (1) including Air Proving Switch and Contact Board:  
EACK1620-A upgrades to EASASD-12AS  
EACK1625-A upgrades to EASASD-11AS  
EACK2020-A upgrades to EASASD-12AS  
EACK2025-A upgrades to EASASD-18AS

\* MERV: Minimum Efficiency Reporting Value. Based on ASHRAE Standard 52.2.

## SPECIFICATIONS

MODEL	EAMU1620-A	EAMU1625-A	EAMU2020-A	EAMU2025-A
<b>Power Consumption</b>	0	0	0	0
<b>House Size</b>	<2400 ft <sup>2</sup> <222.96 m <sup>2</sup>	<3000 ft <sup>2</sup> <278.70 m <sup>2</sup>	<3000 ft <sup>2</sup> <278.70 m <sup>2</sup>	>3000 ft <sup>2</sup> >278.70 m <sup>2</sup>
<b>Air Flow</b>	up to 1200 cfm up to 2039 m <sup>3</sup> /hr	up to 1400 cfm up to 2379 m <sup>3</sup> /hr	up to 1400 cfm up to 2379 m <sup>3</sup> /hr	up to 2000 cfm up to 3398 m <sup>3</sup> /hr
<b>Duct Size</b>	16 x 20 in 40.5 x 51 cm	16 x 25 in 40.5 x 63.5 cm	20 x 20 in 51 x 51 cm	20 x 25 in 51 x 63.5 cm
<b>Intake Dimensions H x L</b>	13.12 x 20.68 in 33.3 x 52.5 cm	13.62 x 24.11 in 34.6 x 61.2 cm	18.0 x 18.71 in 45.7 x 47.5 cm	18.0 x 23.26 in 45.7 x 59.1 cm
<b>Cabinet Dimensions W x H x L</b>	7.5 x 17.41 x 23.75 in 19.05 x 44.2 x 60.3 cm	7.5 x 17.41 x 26.64 in 19.1 x 44.2 x 67.3 cm	7.5 x 22.3 x 21.75 in 19.05 x 56.6 x 55.2 cm	7.5 x 22.3 x 26.29 in 19.05 x 56.6 x 66.8 cm
<b>Weight</b>	17 lbs 7.7 kg	18 lbs 8.2 kg	19 lbs 8.6 kg	20 lbs 9.1 kg
<b>Pressure Drop</b>	.064 (in./wg) @ 246 fpm .209 (in./wg) @ 492 fpm	.066 (in./wg) @ 246 fpm .217 (in./wg) @ 492 fpm	.062 (in./wg) @ 246 fpm .203 (in./wg) @ 492 fpm	.069 (in./wg) @ 246 fpm .207 (in./wg) @ 492 fpm
<b>MERV Rating</b>	11	11	11	11

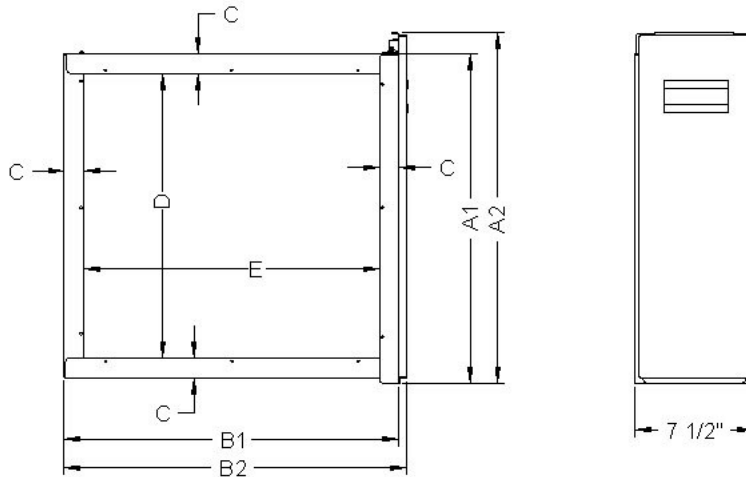

MODEL	DIMENSIONS in (cm)						
	A1	A2	B1	B2	C	D	E
<b>EAMU1620-A</b>	15.94 (40.5)	17.41 (44.2)	23.18 (58.9)	23.7 (60.2)	1.25 (3.2)	13.12 (33.3)	20.68 (52.5)
<b>EAMU1625-A</b>	15.94 (40.5)	17.41 (44.2)	26.11 (66.3)	26.64 (67.7)	1.0 (2.6)	13.62 (34.6)	24.11 (61.2)
<b>EAMU2020-A</b>	20.83 (52.9)	22.3 (56.6)	21.21 (53.9)	21.74 (55.2)	1.25 (3.2)	18.0 (45.7)	18.71 (47.5)
<b>EAMU2025-A</b>	20.83 (52.9)	22.3 (56.6)	25.76 (65.5)	26.29 (66.8)	1.25 (3.2)	18.0 (45.7)	23.26 (59.1)

Manufacturer reserves the right to discontinue or change at any time, specifications or designs without notice or without incurring obligations. Performance of the Air Cleaners will depend on house plan design, duct design and heating/cooling equipment.



**ELECTRO-AIR CANADA**  
 351 North Rivermede Road, Concord, Ontario, Canada L4K 3N2  
 Tel: (416) 213-5636 Fax: (416) 213-5593  
 Toll Free: (800) 267-8305  
 info@fiveseasonsaircleaners.com www.fiveseasonsaircleaners.com



## WHOLE-HOUSE GREEN EFFICIENCY MEDIA RETROFIT AIR CLEANERS

### Description

- The Electro-Air Green Efficiency Media Retrofit Air Cleaner has been designed to meet the air filtration efficiency criteria required to gain points toward certification in the Leadership in Energy and Environmental Design (LEED) Green Building rating system.
- Removes atmospheric and household dust, coal dust, insecticide dust, mites, pollen, mold spores, fungi, bacteria, pet dander, cooking smoke and grease, tobacco smoke particles, and more down to 0.3 micron (1/84,000 of an inch).
- Ideal for homes with allergy, asthma or respiratory sufferers, smokers, pets and mustiness. Also ideal for commercial applications.
- Helps protect and prolong the operating efficiency of the heating and cooling equipment, plus it keeps coils, diffusers and ductwork much cleaner.

### Standard Features

- High Efficiency MERV\* 14 Media Filter, rated at 492 feet/minute, removes airborne contaminants down to 0.3 micron on the first pass of air.
- Filter material is constructed with an advanced synthetic air media that utilizes both charged fibers and traditional mechanical filtration principles. The charged fibers allow the media to achieve MERV 14 levels upon installation and immediately grab and trap airborne contaminants. The resulting dust cake then enhances the mechanical principles of the filter allowing for high levels of filtration during the entire life-cycle.
- Extra deep, 5 1/4 inch, 24 pleat filter contains more media material than other filters on the market.
- More surface area means more collection area, longer filter life and lower static pressure.
- Perfect fit filter has an exact fit with the cabinet. Does not contain foam, sponge or fiberglass filler. Means all the air is passing through the filter and not through filler material, thereby maximizing the system's ability to clean the air.
- User-friendly, easy-to-change filter cartridge means no fussing with complicated combs or brackets.



- Filter lasts up to one year in standard applications.
- Reversible air flow. Mounts in any position.
- Easily upgrades to the Electro-Air "D Series" High Efficiency Electronic Air Cleaner, which is capable of removing harmful contaminants as small as 0.01 micron (1/2,540,000 of an inch).
- Limited 5 Year Warranty.

### Cabinet Construction Features

- Heavy gauge galvanized steel cabinet resists corrosion and provides trouble-free vertical or horizontal installation. Holes are provided to facilitate mounting to the duct work or air handling system.
- Durable powder coat paint finish on door resists corrosion.

### Media Replacement Filters

- Replacement filters are packaged 3 per box. Replace 1 to 2 times per year depending on climate, home renovations, smoking in home, or number of pets. For models:  
 EA14MU1625-A replace with Part #G1-1056  
 EA14MU2025-A replace with Part #G8-1056

### Accessories

- Activated Carbon Filters (3 per pack) help eliminate unpleasant odours. Replace every 3-6 months. For models:  
 EA14MU1625-A Part #1156-3  
 EA14MU2025-A Part #1856-3
- Upgrade Kit to Electronic Air Cleaner includes Prefilters (2), Collecting Cells (2), Power Box (1) including Air Proving Switch and Contact Board:  
 EACK1625-A upgrades to EASASD-11  
 EACK2025-A upgrades to EASASD-18

\* MERV: Minimum Efficiency Reporting Value. Based on ASHRAE Standard 52.2.

## SPECIFICATIONS

MODEL	EA14MU1625-A	EA14MU2025-A
<b>Power Consumption</b>	0	0
<b>House Size</b>	<3000 ft <sup>2</sup> <278.70 m <sup>2</sup>	>3000 ft <sup>2</sup> >278.70 m <sup>2</sup>
<b>Air Flow</b>	up to 1400 cfm up to 2379 m <sup>3</sup> /hr	up to 2000 cfm up to 3398 m <sup>3</sup> /hr
<b>Duct Size</b>	16 x 25 in 40.5 x 63.5 cm	20 x 25 in 51 x 63.5 cm
<b>Intake Dimensions</b> <i>H x L</i>	13.62 x 24.11 in 34.6 x 61.2 cm	18.0 x 23.26 in 45.7 x 59.1 cm
<b>Cabinet Dimensions</b> <i>W x H x L</i>	7.5 x 17.41 x 26.64 in 19.1 x 44.2 x 67.3 cm	7.5 x 22.3 x 26.29 in 19.05 x 56.6 x 66.8 cm
<b>Weight</b>	18 lbs 8.2 kg	20 lbs 9.1 kg
<b>Pressure Drop</b>	.10 (in./wg) @ 684 cfm .28 (in./wg) @ 1367 cfm	.09 (in./wg) @ 854 cfm .24 (in./wg) @ 1708 cfm
<b>MERV Rating</b>	14	14
<b>Efficiency On Micron Size</b>		
E1 (0.3 - 1.0 micron)	82%	85%
E2 (1.0 - 3.0 micron)	97%	98%
E3 (3.0 - 10.0 micron)	99%	99%

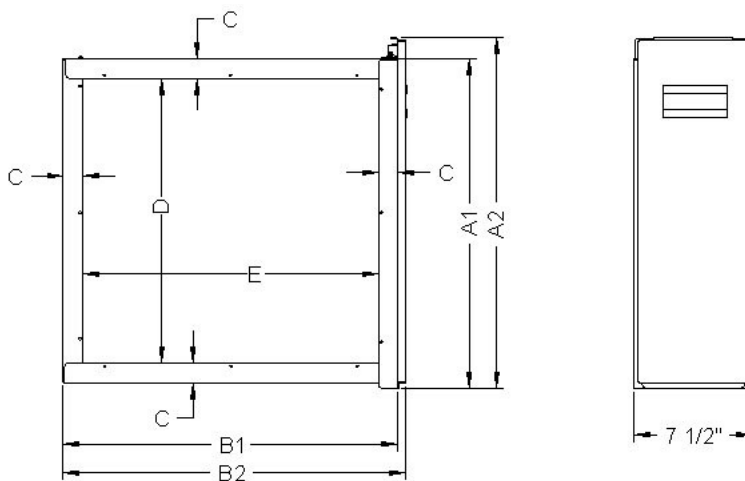

MODEL	DIMENSIONS in (cm)						
	A1	A2	B1	B2	C	D	E
<b>EA14MU1625-A</b>	15.94 (40.5)	17.41 (44.2)	26.11 (66.3)	26.64 (67.7)	1.0 (2.6)	13.62 (34.6)	24.11 (61.2)
<b>EA14MU2025-A</b>	20.83 (52.9)	22.3 (56.6)	25.76 (65.5)	26.29 (66.8)	1.25 (3.2)	18.0 (45.7)	23.26 (59.1)

Manufacturer reserves the right to discontinue or change at any time, specifications or designs without notice or without incurring obligations. Performance of the Air Cleaners will depend on house plan design, duct design and heating/cooling equipment.



**ELECTRO-AIR CANADA**  
 351 North Rivermede Road, Concord, Ontario, Canada L4K 3N2  
 Tel: (416) 213-5636 Fax: (416) 213-5593  
 Toll Free: (800) 267-8305  
 info@fiveseasonsaircleaners.com www.fiveseasonsaircleaners.com





## WHOLE-HOUSE HIGH EFFICIENCY MEDIA AIR CLEANERS

### Description

- The Electro-Air High Efficiency Media Air Cleaner has been designed to remove atmospheric and household dust, coal dust, insecticide dust, mites, pollen, mold spores, fungi, bacteria, pet dander, cooking smoke and grease, tobacco smoke particles, and more down to 0.3 micron (1/84,000 of an inch).
- Ideal for homes with allergy, asthma or respiratory sufferers, smokers, pets and mustiness.
- Helps protect and prolong the operating efficiency of the heating and cooling equipment.

### Standard Features

- High Efficiency MERV\* 11 Media Filter, rated at 492 feet/minute, removes airborne contaminants down to 0.3 micron.
- Filter material is constructed of continuous hydrophobic polyolefin fibers that will not shred or absorb moisture. They are cellulose free and will not sustain mold growth.
- Unique filter design features a structured density gradient with an electret charge for higher initial and sustained efficiency over the life of the filter.
- Extra deep, 5¼ inch filter, contains more media material than other filters on the market. More surface area means more collection area, longer filter life and lower static pressure.
- Perfect fit filter has an exact fit with the cabinet. Does not contain foam, sponge or fiberglass filler. Means all the air is passing through the filter and not through filler material, thereby maximizing the system's ability to clean the air.
- User-friendly, easy-to-change filter cartridge means no fussing with complicated combs or brackets.
- Filter lasts up to one year in standard applications.
- Reversible air flow. Mounts in any position.



- Easy to replace with an Electro-Air High Efficiency Electronic Air Cleaner, which is capable of removing harmful contaminants as small as 0.01 micron (1/2,540,000 of an inch). For the most powerful air cleaning system available, add an Electro-Air True HEPA Air Cleaner to the Electro-Air Media or Electronic Air Cleaner.
- Limited 5 Year Warranty.

### Cabinet Construction Features

- Heavy gauge galvanized steel cabinet resists corrosion and provides trouble-free vertical or horizontal installation. Holes are provided to facilitate mounting to the duct work or air handling system.
- Durable powder coat paint finish on door resists corrosion.

### Media Replacement Filters

- Replacement filters are packaged 3 per box. Replace 1 to 2 times per year depending on climate, home renovations, smoking in home, or number of pets. For models:  
EANC1620-A replace with #M0-1056 (MERV 11)  
EANC1625-A replace with #M1-1056 (MERV 11) or G1-1056 (MERV 14) upgrade  
EANC2020-A replace with #M2-1056 (MERV 11)  
EANC2025-A/EANC2520-A replace with #M8-1056 (MERV 11) or G8-1056 (MERV 14) upgrade

\* MERV: Minimum Efficiency Reporting Value. Based on ASHRAE Standard 52.2.

## SPECIFICATIONS

MODEL	EANC1620-A	EANC1625-A	EANC2020-A	EANC2025-A	EANC2520-A
<b>Power Consumption</b>	0	0	0	0	0
<b>House Size</b>	<2400 ft <sup>2</sup> <222.96 m <sup>2</sup>	<3000 ft <sup>2</sup> <278.7 m <sup>2</sup>	<3000 ft <sup>2</sup> <278.7 m <sup>2</sup>	>3000 ft <sup>2</sup> >278.7 m <sup>2</sup>	>3000 ft <sup>2</sup> >278.7 m <sup>2</sup>
<b>Air Flow</b>	up to 1200 cfm up to 2038 m <sup>3</sup> /hr	up to 1400 cfm up to 2379 m <sup>3</sup> /hr	up to 1400 cfm up to 2379 m <sup>3</sup> /hr	up to 2000 cfm up to 3398 m <sup>3</sup> /hr	up to 2000 cfm up to 3398 m <sup>3</sup> /hr
<b>Duct Size</b>	16 x 20 in 40.5 x 51 cm	16 x 25 in 40.6 x 63.5 cm	20 x 20 in 51 x 51 cm	20 x 25 in 51 x 63.5 cm	25 x 20 in 63.5 x 51 cm
<b>Intake Dimensions H x L</b>	13.25 x 20.75 in 33.7 x 52.7 cm	13.25 x 23.7 in 33.7 x 60.2 cm	18.1 x 18.75 in 46 x 47.6 cm	18.1 x 23.25 in 46 x 59.1 cm	23.05 x 18.25 in 58.5 x 46.4 cm
<b>Cabinet Dimensions W x H x L</b>	7.5 x 17.4 x 23.6 in 19.1 x 44.2 x 60 cm	7.5 x 17.4 x 26.5 in 19.1 x 44.2 x 67.3 cm	7.5 x 22.25 x 21.7 in 19.1 x 56.5 x 55.1 cm	7.5 x 22.25 x 26.1 in 19.1 x 56.5 x 66.3 cm	7.5 x 27.3 x 21.2 in 19.1x69.4x53.9 cm
<b>Weight</b>	17 lbs 7.7 kg	18 lbs 8.2 kg	19 lbs 8.6 kg	20 lbs 9.1 kg	20 lbs 9.1 kg
<b>Pressure Drop</b>	.064 (in./wg) @ 246 fpm .209 (in./wg) @ 492 fpm	.066 (in./wg) @ 246 fpm .217 (in./wg) @ 492 fpm	.062 (in./wg) @ 246 fpm .203 (in./wg) @ 492 fpm	.069 (in./wg) @ 246 fpm .207 (in./wg) @ 492 fpm	.069 (in./wg) @ 246 fpm .207 (in./wg) @ 492 fpm
<b>MERV Rating</b>	11	11	11	11	11
<b>Replacement Filter</b>	M0-1056	M1-1056	M2-1056	M8-1056	M8-1056

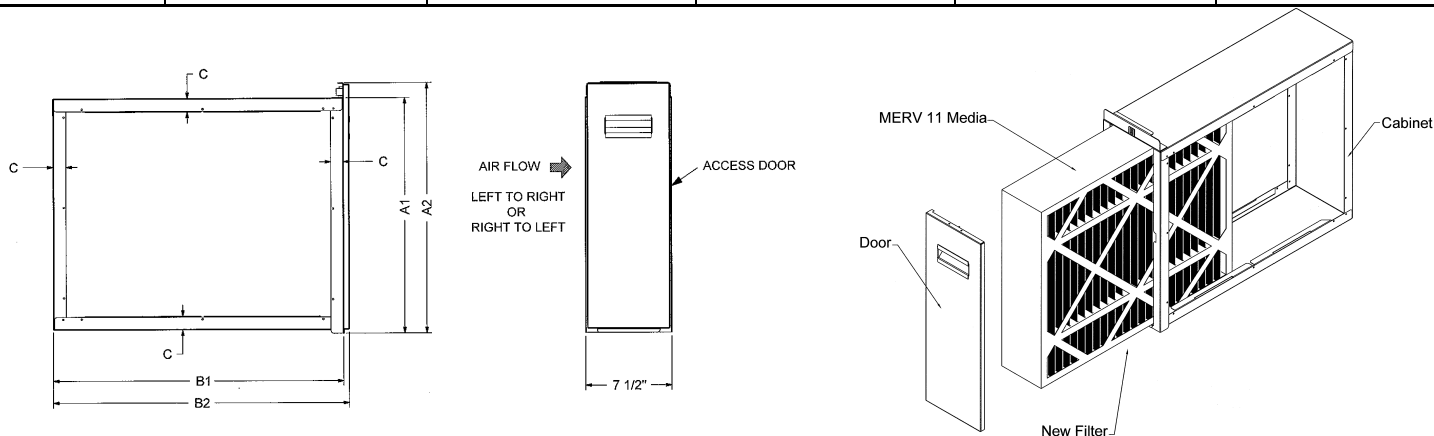

MODEL	DIMENSIONS in (cm)						
	A1	A2	B1	B2	C	D	E
<b>EANC1620-A</b>	16 (40.6)	17.4 (44.2)	23.1 (58.7)	23.6 (60)	1.2 (3)	20.75 (52.7)	13.25 (33.7)
<b>EANC1625-A</b>	16 (40.6)	17.4 (44.2)	26 (66)	26.5 (67.3)	1.2 (3)	23.7 (60.2)	13.25 (33.7)
<b>EANC2020-A</b>	20.75 (52.7)	22.25 (56.5)	21.2 (53.8)	21.7 (55.1)	1.2 (3)	18.75 (47.6)	18.1 (46)
<b>EANC2025-A</b>	20.75 (52.7)	22.25 (56.5)	25.6 (65)	26.1 (66.3)	1.2 (3)	23.25 (59.1)	18.1 (46)
<b>EANC2520-A</b>	25.87 (65.7)	27.32 (69.4)	20.68 (52.5)	21.21 (53.9)	1.25 (3.2)	23.05 (58.5)	18.25 (46.4)

Manufacturer reserves the right to discontinue or change at any time, specifications or designs without notice or without incurring obligations. Performance of the Air Cleaners will depend on house plan design, duct design and heating/cooling equipment.



**ELECTRO-AIR CANADA**  
 351 North Rivermede Road, Concord, Ontario, Canada L4K 3N2  
 Tel: (416) 213-5636 Fax: (416) 213-5593  
 Toll Free: (800) 267-8305  
[info@fiveseasonsaircleaners.com](mailto:info@fiveseasonsaircleaners.com) [www.fiveseasonsaircleaners.com](http://www.fiveseasonsaircleaners.com)



## PERFECT CLEAN-FIT MEDIA AIR CLEANERS FOR ALL NEW FURNACE & AIR HANDLER SIZES

**NEW**

### Description

- The new generation of Electro-Air Media Air Cleaners have been intuitively designed with outer dimensions that match original equipment furnace and air handler cabinets for quick installation (almost all brands on the market).
- Designed to remove atmospheric and household dust, coal dust, insecticide dust, mites, pollen, mold spores, fungi, bacteria, pet dander, cooking smoke and grease, tobacco smoke particles, and more down to 0.3 micron (1/84,000 of an inch).
- Ideal for homes with allergy, asthma or respiratory sufferers, smokers, pets and mustiness.
- Helps protect and prolong the operating efficiency of the heating and cooling equipment.

### Standard Features

- Includes High Efficiency MERV\* 11 Media Filter, rated at 492 feet/minute, removes airborne contaminants down to 0.3 micron.
- Filter material is constructed of cellulose-free, continuous hydrophobic polyolefin fibers that will not shred or absorb moisture.
- Unique filter design features a structured density gradient with an electret charge for higher initial and sustained efficiency over the life of the filter.
- Extra deep, 5¼ inch filter, contains more media material than other filters on the market. More surface area means more collection area, longer filter life and lower static pressure.
- Perfect fit filter has a tight fit with the cabinet. Does not contain foam, sponge or fiberglass filler. Means all the air is passing through the filter and not through filler material, thereby maximizing the system's ability to clean the air.
- User-friendly, easy-to-change filter cartridge means no fussing with complicated combs or brackets.
- Filter lasts up to one year in standard applications.
- Reversible air flow. Mounts in any position.
- Limited 5 Year Warranty.



### Cabinet Construction Features

- Heavy gauge galvanized steel cabinet resists corrosion and provides trouble-free vertical or horizontal installation. Holes are provided to facilitate mounting to the duct work or air handling system.
- Durable powder coat paint finish on door resists corrosion.

### Media Replacement Filters

	Air Cleaner Model	Replacement Filter
<b>Furnaces</b>	EAMA11-1428-FA	MAH-1056A
	EAMA11-1728-FB	M1-1056
	EAMA11-2128-FC	M8-1056
	EAMA11-2428-FD	M8-1056
<b>Air Handlers</b>	EAMA11-1422-AA	MAH-1056A
	EAMA11-1722-AB	MFAH-S
	EAMA11-2022-AC	MFAH-M
	EAMA11-2122-AC	M2-1056
	EAMA11-2422-AD	MAH-1056C

\* MERV: Minimum Efficiency Reporting Value. Based on ASHRAE Standard 52.2.

## SPECIFICATIONS

MODEL	EAMA11-1428-FA	EAMA11-1728-FB	EAMA11-2128-FC	EAMA11-2428-FD	EAMA11-1422-AA	EAMA11-1722-AB	EAMA11-2022-AC	EAMA11-2122-AC	EAMA11-2422-AD
<b>Power Consumption</b>	0	0	0	0	0	0	0	0	0
<b>House Size</b>	<2400 ft <sup>2</sup> <222.96 m <sup>2</sup>	<3000 ft <sup>2</sup> <278.70 m <sup>2</sup>	<3000 ft <sup>2</sup> <278.70 m <sup>2</sup>	>3000 ft <sup>2</sup> >278.70 m <sup>2</sup>	<2400 ft <sup>2</sup> <222.96 m <sup>2</sup>	<3000 ft <sup>2</sup> <278.70 m <sup>2</sup>	<3000 ft <sup>2</sup> <278.70 m <sup>2</sup>	<3000 ft <sup>2</sup> <278.70 m <sup>2</sup>	>3000 ft <sup>2</sup> >278.70 m <sup>2</sup>
<b>Air Flow</b>	up to 1200 cfm up to 2039 m <sup>3</sup> /h	up to 1400 cfm up to 2379 m <sup>3</sup> /h	up to 2000 cfm up to 3398 m <sup>3</sup> /h	up to 2000 cfm up to 3398 m <sup>3</sup> /h	up to 1200 cfm up to 2039 m <sup>3</sup> /h	up to 1400 cfm up to 2379 m <sup>3</sup> /h	up to 1400 cfm up to 2379 m <sup>3</sup> /h	up to 1400 cfm up to 2379 m <sup>3</sup> /h	up to 2000 cfm up to 3398 m <sup>3</sup> /hr
<b>Furnace Base Size</b>	14 x 28 in 35.6 x 71.1 cm	17 x 28 in 43.2 x 71.1 cm	21 x 28 in 53.3 x 71.1 cm	24 x 28 in 61 x 71.1cm	14 x 22 in 35.6 x 55.9cm	17 x 22 in 43.2 x 55.9 cm	20 x 22 in 50.8 x 55.9 cm	21 x 22 in 53.3 x 55.9cm	24 x 22 in 61 x 55.9 cm
<b>Intake Dimensions H x L</b>	12.5 x 25.5 in 31.8 x 64.8 cm	15 x 25.5 in 38.1 x 64.8 cm	18.5 x 25.5 in 46.9 x 64.8 cm	22 x 25.5 in 55.9 x 64.8 cm	12.5 x 19.75 in 31.8 x 50.2 cm	15 x 19.75 in 38.1 x 50.2 cm	18 x 19.75 in 46.9 x 50.2 cm	18.5 x 19.75 in 47 x 50.2	22 x 19.75 in 55.9 x 50.2 cm
<b>Cabinet Dimensions W x H x L</b>	7.59 x 15 x 28.5 in 19.3 x 38.1 x 72.4 cm	7.59 x 17.5 x 28.5 in 19.3 x 44.5 x 72.4 cm	7.59 x 21 x 28.5 in 19.3 x 53.3 x 72.4 cm	7.59 x 24.5 x 28.5 in 19.3 x 62.2 x 72.4 cm	7.59 x 15 x 22.75 in 19.3 x 28.1 x 57.8cm	7.59 x 17.5 x 22.75 in 19.3 x 44.5 x 57.8 cm	7.59 x 20.5 x 22.75 in 19.3 x 52.1 x 57.8 cm	7.59 x 21 x 22.75 in 19.3 x 53.3 x 57.8 cm	7.59 x 24.5 x 22.75 in 19.3 x 62.2 x 57.8 cm
<b>Weight</b>	17 lbs 7.7 kg	18 lbs 8.2 kg	19 lbs 8.6 kg	20 lbs 9.1 kg	17 lbs 7.7 kg	18 lbs 8.2 kg	19 lbs 8.6 kg	19 lbs 8.6 kg	20 lbs 9.1 kg
<b>Pressure Drop</b>	.064 (in./wg) @ 246 fpm .209 (in./wg) @ 492 fpm	.066 (in./wg) @ 246 fpm .217 (in./wg) @ 492 fpm	.062 (in./wg) @ 246 fpm .203 (in./wg) @ 492 fpm	.069 (in./wg) @ 246 fpm .207 (in./wg) @ 492 fpm	.064 (in./wg) @ 246 fpm .209 (in./wg) @ 492 fpm	.066 (in./wg) @ 246 fpm .217 (in./wg) @ 492 fpm	.062 (in./wg) @ 246 fpm .203 (in./wg) @ 492 fpm	.062 (in./wg) @ 246 fpm .203 (in./wg) @ 492 fpm	.069 (in./wg) @ 246 fpm .207 (in./wg) @ 492 fpm
<b>MERV Rating</b>	11	11	11	11	11	11	11	11	11

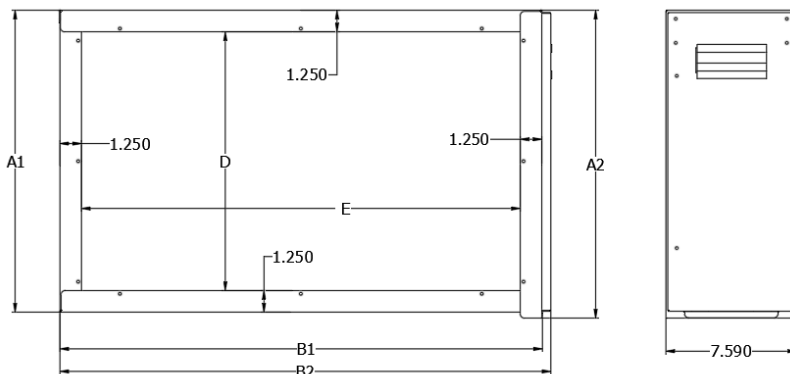

MODEL	DIMENSIONS in (cm)					
	A1	B1	A2	B2	D	E
<b>EAMA11-1428-FA</b>	15.0 (38.1)	28.0 (71.1)	15.35 (39.0)	28.5 (72.4)	12.5 (31.8)	25.5 (64.8)
<b>EAMA11-1728-FB</b>	17.5 (44.5)	28.0 (71.1)	17.85 (45.3)	28.5 (72.4)	15.0 (38.1)	25.5 (64.8)
<b>EAMA11-2128-FC</b>	21.0 (53.4)	28.0 (71.1)	21.35 (54.2)	28.5 (72.4)	18.5 (47.0)	25.5 (64.8)
<b>EAMA11-2428-FD</b>	24.5 (62.2)	28.0 (71.1)	24.85 (63.1)	28.5 (72.4)	22.0 (55.9)	25.5 (64.8)
<b>EAMA11-1422-AA</b>	15.0 (38.1)	22.25 (56.5)	15.35 (39.0)	22.75 (57.8)	12.5 (31.8)	19.75 (50.2)
<b>EAMA11-1722-AB</b>	17.5 (44.5)	22.25 (56.5)	17.85 (45.3)	22.75 (57.8)	15.0 (38.1)	19.75 (50.2)
<b>EAMA11-2022-AC</b>	20.5 (52.1)	22.25 (56.5)	20.85 (53.0)	22.75 (57.8)	18.0 (45.7)	19.75 (50.2)
<b>EAMA11-2122-AC</b>	21.0 (53.3)	22.25 (56.5)	21.35 (54.2)	22.75 (57.8)	18.5 (47.0)	19.75 (50.2)
<b>EAMA11-2422-AD</b>	24.5 (62.2)	22.25 (56.5)	24.85 (63.1)	22.75 (57.8)	22.0 (55.9)	19.75 (50.2)

Manufacturer reserves the right to discontinue or change at any time, specifications or designs without notice or without incurring obligations. Performance of the Air Cleaners will depend on house plan design, duct design and heating/cooling equipment.



**ELECTRO-AIR CANADA**  
 351 North Rivermede Road, Concord, Ontario, Canada L4K 3N2  
 Tel: (416) 213-5636 Fax: (416) 213-5593  
 Toll Free: (800) 267-8305  
 info@fiveseasonsaircleaners.com www.fiveseasonsaircleaners.com



## **WHOLE-HOUSE, TOP LOADING HIGH EFFICIENCY MEDIA AIR CLEANER**

### **Description**

- The Electro-Air Top Loading High Efficiency Media Air Cleaner has been designed to remove atmospheric and household dust, coal dust, insecticide dust, mites, pollen, mold spores, fungi, bacteria, pet dander, cooking smoke and grease, tobacco smoke particles, and more down to 0.3 micron (1/84,000 of an inch).
- Ideal for homes with allergy, asthma or respiratory sufferers, smokers, pets and mustiness.
- Helps protect and prolong the operating efficiency of the heating and cooling equipment.

### **Standard Features**

- High Efficiency MERV\*\* 11 Media Filter, rated at 492 feet/minute, removes airborne contaminants down to 0.3 micron.
- Filter material is constructed of continuous hydrophobic polyolefin fibers that are thermally bonded and will not shred or absorb moisture. They are cellulose free and will not sustain mold growth.
- Unique filter design features a structured density gradient with an electret charge for higher initial and sustained efficiency over the life of the filter.
- Extra deep, 5¼ inch filter contains more media material than other filters on the market. More surface area means more collection area, longer filter life and lower static pressure.
- Perfect fit filter has an exact fit with the cabinet. Does not contain foam, sponge or fiberglass filler. Means all the air is passing through the filter and not through filler material, thereby maximizing the system's ability to clean the air.
- User-friendly, easy-to-change filter cartridge means no fussing with complicated combs or brackets.
- Filter lasts up to one year in standard applications.
- For the most powerful air cleaning system available, add a True HEPA Air Cleaner to the Media or Electronic Air Cleaner.
- Limited 5 Year Warranty.

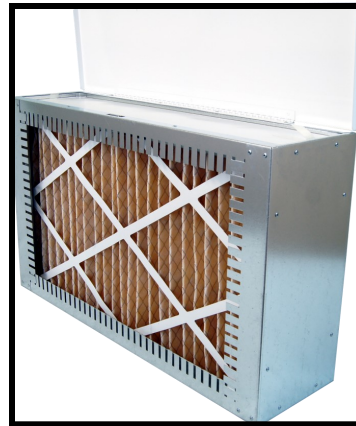

**MERV 11**

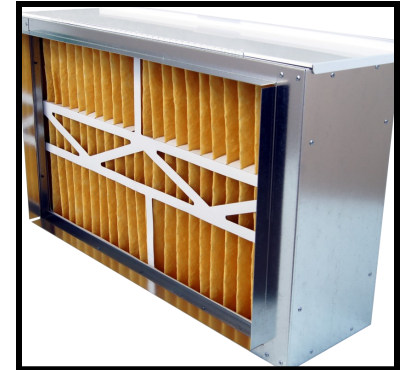

### **Cabinet Construction Features**

- Top Loading Filter. Ideal for installations where there are space restrictions in front of air cleaner.
- Hinged door with magnetic latch provides a tight seal.
- Powder coat paint finish on door resists corrosion.
- Heavy gauge galvanized steel cabinet resists corrosion and provides trouble-free vertical installation. Flanges are provided to facilitate mounting to the duct work or air handling system.

### **Media Replacement Filters**

- Replacement filters are packaged 3 per box. Replace 1 to 2 times per year depending on climate, home renovations, smoking in home, or number of pets. For model:
- Upgradable to MERV14.

EAMEDIA1625TL replace with Part #M1-1056  
MERV 14 Part #G1-1056

\* Not including filter.

\*\* MERV: Minimum Efficiency Reporting Value. Based on ASHRAE Standard 52.2.

## SPECIFICATIONS

MODEL	EAMEDIA-1625TL
<b>Power Consumption</b>	0
<b>House Size</b>	<3000 ft <sup>2</sup> <278.7 m <sup>2</sup>
<b>Air Flow</b>	up to 1400 cfm up to 2379 m <sup>3</sup> /hr
<b>Duct Size</b>	16 x 25 in 40.6 x 63.5 cm
<b>Intake Dimensions</b> <i>H x L</i>	13.25 x 23.7 in 33.7 x 60.2 cm
<b>Cabinet Dimensions</b> <i>W x H x L</i>	7.5 x 17.4 x 26.5 in 19.1 x 44.2 x 67.3 cm
<b>Weight</b>	18 lbs 8.2 kg
<b>Pressure Drop</b>	.066 (in./wg) @ 246 fpm .217 (in./wg) @ 492 fpm
<b>MERV Rating</b>	11

MODEL	DIMENSIONS in (cm)				
	Height	Length	Width	Opening Height	Opening Length
EAMEDIA-1625TL	16.5 (41.9)	26.5 (67.3)	7.5 (19.1)	14 (35.6)	23 (58.4)

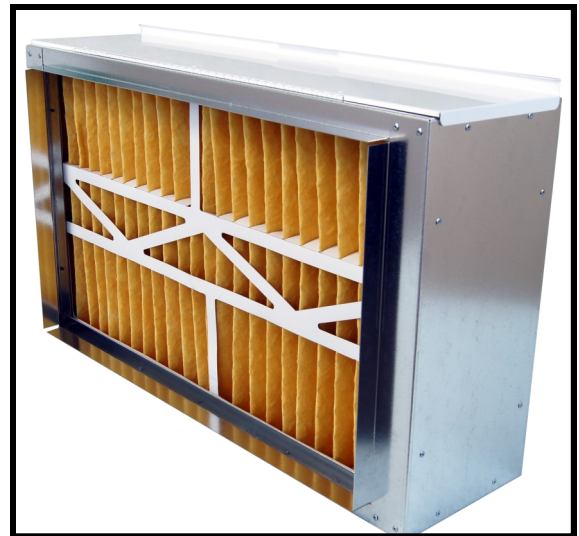

Manufacturer reserves the right to discontinue or change at any time, specifications or designs without notice or without incurring obligations. Performance of the Air Cleaners will depend on house plan design, duct design and heating/cooling equipment.

**Breathe Clean**  
Live Green

**ELECTRO-AIR CANADA**  
351 North Rivermede Road, Concord, Ontario, Canada L4K 3N2  
Tel: (416) 213-5636 Fax: (416) 213-5593  
Toll Free: (800) 267-8305  
info@fiveseasonsaircleaners.com www.fiveseasonsaircleaners.com

**PROUDLY MADE IN CANADA**

## **LIGHT COMMERCIAL OVER-SIZED HIGH EFFICIENCY MEDIA AIR CLEANER**

### **Description**

- The Electro-Air Over-sized High Efficiency Media Air Cleaner has been designed for 5 ton horizontal air handler/ furnace applications to remove atmospheric and household dust, coal dust, insecticide dust, mites, pollen, mold spores, fungi, bacteria, pet dander, cooking smoke and grease, tobacco smoke particles, and more down to 0.3 micron (1/84,000 of an inch).
- Ideal for commercial applications.
- Helps protect and prolong the operating efficiency of the heating and cooling equipment.

### **Standard Features**

- High Efficiency MERV\* 11 Media Filter, rated at 492 feet/minute, removes airborne contaminants down to 0.3 micron.
- Filter material is constructed of continuous hydrophobic polyolefin fibers that will not shred or absorb moisture. They are cellulose free and will not sustain mold growth.
- Unique filter design features a structured density gradient with an eletret charge for higher initial and sustained efficiency over the life of the filter.
- Contains two (2) extra deep, 5¼ inch pleated filters containing more media material than other filters on the market. More surface area means more collection area, longer filter life and lower static pressure.
- Perfect fit filters have an exact fit with the cabinet. Does not contain foam, sponge or fiberglass filler. Means all the air is passing through the filters and not through filler material, thereby maximizing the system's ability to clean the air.
- User-friendly, easy-to-change filter cartridge means no fussing with complicated combs or brackets.
- Filters last up to one year in standard applications.
- Mounts vertically or on its back.
- Limited 5 Year Warranty.



### **Cabinet Construction Features**

- Heavy gauge galvanized steel cabinet resists corrosion and provides trouble-free vertical or horizontal installation. Holes are provided to facilitate mounting to the duct work or air handling system.
- Durable powder coat paint finish on door resists corrosion.
- 1" mounting flange on intake and exhaust.

### **Media Replacement Filters**

- Replacement filters are packaged 3 per box. Replace 1 to 2 times per year depending on climate, home renovations, smoking in home, or number of pets.  
Requires (2) M1-1056 Filters

\* **MERV:** Minimum Efficiency Reporting Value. Based on ASHRAE Standard 52.2.

## SPECIFICATIONS

MODEL	EAMF3225
<b>Power Consumption</b>	0
<b>House Size</b>	>3000 ft <sup>2</sup> >278.7 m <sup>2</sup>
<b>Air Flow</b>	up to 2800 cfm up to 2379 m <sup>3</sup> /hr
<b>Duct Size</b>	32 x 25 in 81.2 x 63.5 cm
<b>Intake Dimensions</b> <i>H x L</i>	28 x 23 in 71.1 x 58.4 cm
<b>Cabinet Dimensions</b> <i>W x H x L</i>	26.7 x 33 x 7.5 in 67.8 x 83.8 x 19 cm
<b>Weight</b>	21 lbs 9.5 kg
<b>MERV Rating</b>	11
<b>Pressure Drop</b>	.040 (in./wg) @ 1000 cfm 0.135 (in./wg) @ 2000 cfm
<b>Options Available</b>	G1-1056 MERV 14 Replacement Filter Requires 2

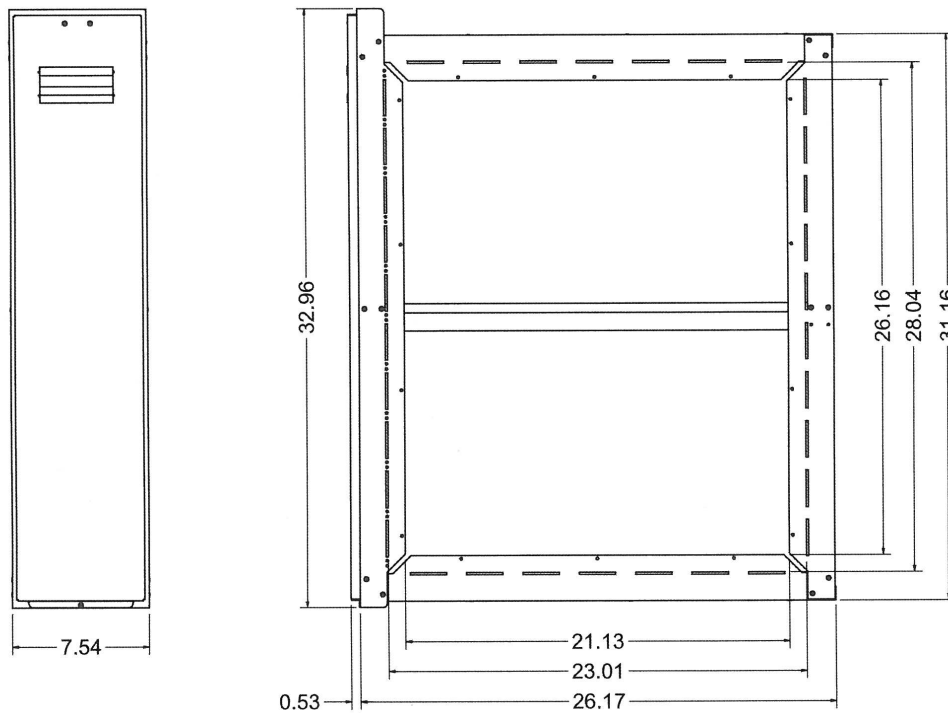

Manufacturer reserves the right to discontinue or change at any time, specifications or designs without notice or without incurring obligations. Performance of the Air Cleaners will depend on house plan design, duct design and heating/cooling equipment.



### ELECTRO-AIR CANADA

351 North Rivermede Road, Concord, Ontario, Canada L4K 3N2

Tel: (416) 213-5636 Fax: (416) 213-5593

Toll Free: (800) 267-8305

info@fiveseasonsaircleaners.com

www.fiveseasonsaircleaners.com





## WHOLE-HOUSE RIGHT ANGLE MEDIA (RAM) AIR CLEANER

### Description

- The Electro-Air High Efficiency Right Angle Media (RAM) Air Cleaner is a space-saving design for vertical installations. Removes atmospheric and household dust, coal dust, insecticide dust, mites, pollen, mold spores, fungi, bacteria, pet dander, cooking smoke and grease, tobacco smoke particles, and more down to 0.3 micron (1/84,000 of an inch).
- Space saving design for vertical installations, reduces installation space by 6-8 inches.
- Eliminates the need for a 90° duct adapter, as it works as a turning vane providing even distribution across the media filter.
- Helps protect and prolong the operating efficiency of the heating and cooling equipment.

### Standard Features

- Adjustable inlet duct opening replaces need for field forming transition, significantly reducing installation time.
- Reversible air flow. Two access doors allow versatile installation and easy maintenance.
- High Efficiency MERV\* 11 Media Filter, rated at 492 feet/minute, removes airborne contaminants down to 0.3 micron.
- Filter material is constructed of continuous hydrophobic polyolefin fibers that will not shred or absorb moisture. They are cellulose free and will not sustain mold growth.
- Unique filter design features a structured density gradient with an electret charge for higher initial and sustained efficiency over the life of the filter.
- Extra deep, 5¼ inch, 24 pleat filter, contains more media material than other filters on the market. More surface area means more collection area, longer filter life and lower static pressure.
- Perfect fit filter allows no air gaps, thereby maximizing the system's ability to clean the air.
- User-friendly, easy-to-change filter cartridge means no fussing with complicated combs or brackets.
- Filter will last up to one year in standard applications.
- Limited 5 Year Warranty.



### Cabinet Construction Features

- Heavy gauge galvanized steel cabinet resists corrosion and provides trouble-free vertical installation. Holes are provided to facilitate mounting to the duct work or air handling system.
- Durable powder coat paint finish on doors (2) resists corrosion.

### Media Replacement Filter

- Replacement filters are packaged 3 per Box. Replace 1 to 2 times per year depending on climate, home renovations, smoking in home, or number of pets.  
EARAM2000 replace with Part #M8-1056 (MERV 11) or G8-1056 (MERV 14)

### Typical Installation

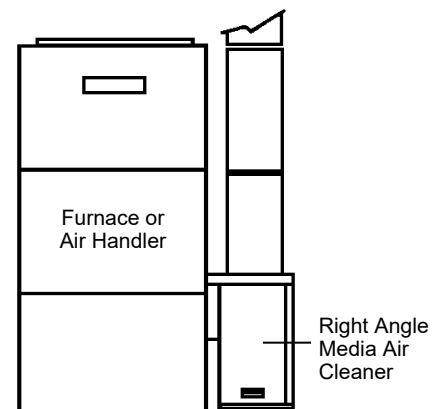

\* MERV: Minimum Efficiency Reporting Value. Based on ASHRAE Standard 52.2.

## SPECIFICATIONS

MODEL	EARAM2000
<b>Power Consumption</b>	0
<b>Air Flow</b>	up to 2000 cfm up to 3398 m <sup>3</sup> /hr
<b>Dimensions (w x d x h)</b>	16 x 26 <sup>3</sup> / <sub>4</sub> x 23 <sup>1</sup> / <sub>2</sub> in 40.6 x 67.9 x 59.7 cm
<b>Adjustable Inlet (3 sizes)</b>	8 x 24 in / 10 x 24 in / 11 x 24 in 20.3 x 61 cm / 25.4 x 61 cm / 27.9 x 61 cm
<b>Outlet (d x h)</b>	23 <sup>1</sup> / <sub>4</sub> x 14 <sup>1</sup> / <sub>4</sub> in 59.1 x 36.2 cm
<b>Unit Weight</b>	34 lbs 15.4 kg
<b>MERV Rating</b>	11

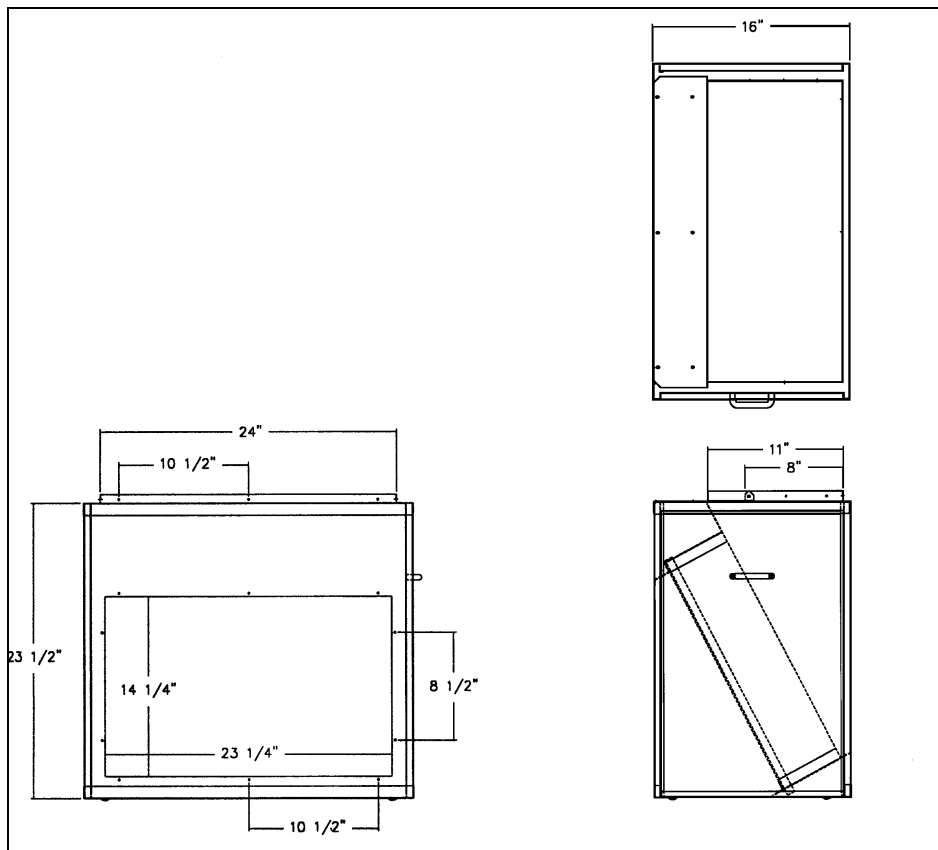

Manufacturer reserves the right to discontinue or change at any time, specifications or designs without notice or without incurring obligations. Performance of the Air Cleaners will depend on house plan design, duct design and heating/cooling equipment.

## UPFLOW BOTTOM SIDE RETURN BASE FOR GAS FURNACES



- Allows furnace to work at maximum efficiency and extends life of furnace by providing air intake through the bottom and side returns where higher air flow is required.
- Allows for a PUR Media or Electronic Air Cleaner to be properly mounted to side of furnace and to work at maximum efficiency.

### Standard Features

- Heavy 22 gauge galvanized sheet metal available in four sizes allowing for a smoother installation.
- Solid one piece wrap cabinet is riveted for sturdiness and long life.
- Available in galvanized sheet metal or powder coat paint finish (Galvanized - G, Painted - P).
- Individually boxed.



### Description

- The *Upflow Bottom Side Return Base* for gas furnaces is the perfect solution for allowing better air flow for any type of variable speed furnace on the market, where a bottom return is preferable, but a side return is necessary.
- Space saving design for vertical installations, keeps furnace off floor allowing a cleaner, more professional installation. Helps eliminate the possibility of dust, pet hair, insects, rodents, water or sewer backup from entering the furnace.

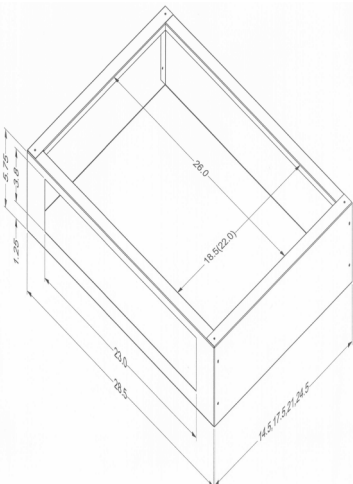

MODEL	FINISH	WIDTH	DEPTH	HEIGHT	WEIGHT (lbs)
<b>EAUSBG1428-G</b>	Galvanized	14½	28½	5¾	8.5
<b>EAUSBG1428-P</b>	Painted	14½	28½	5¾	8.5
<b>EAUSBG1728-G</b>	Galvanized	17½	28½	5¾	10
<b>EAUSBG1728-P</b>	Painted	17½	28½	5¾	10
<b>EAUSBG2128-G</b>	Galvanized	21	28½	5¾	11
<b>EAUSBG2128-P</b>	Painted	21	28½	5¾	11
<b>EAUSBG2428-G</b>	Galvanized	24½	28½	5¾	13
<b>EAUSBG2428-P</b>	Painted	24½	28½	5¾	13

**Breathe Clean**  
Live Green 

### ELECTRO-AIR CANADA

351 North Rivermede Road, Concord, Ontario, Canada L4K 3N2

Tel: (416) 213-5636

Fax: (416) 213-5593

Toll Free: (800) 267-8305

info@fiveseasonsaircleaners.com

www.fiveseasonsaircleaners.com



**PROUDLY MADE IN CANADA**

EAUpflowBottomSideReturnSpec  
01/22



## Description

- The **Perfect-Platform Series** Media Air Cleaners by Electro-Air offer the most well-built, sleek designed and easiest to use galvanized sheet metal filter housings on the market, for residential and light commercial use.
- Space saving design for vertical installations, keeps furnace off floor allowing a cleaner, more professional installation. Eliminates the possibility of dust, pet hair, insects, rodents, water or sewer backup from entering the furnace.
- Allows furnace to work at maximum efficiency and extends life of furnace by providing even air flow distribution across bottom. Especially ideal for high efficiency furnaces, where side returns require more installation time, and are inefficient compared to a bottom return.
- Allows filter to work at maximum efficiency by eliminating need for transitions, deflectors or turning vanes, thereby saving installation time and costs.
- Made to fit 3 to 5 ton gas furnaces or electric air handlers/heat pumps.

- Ideal for homes with allergy, asthma or respiratory sufferers, smokers, pets and mustiness.
- Helps protect and prolong the operating efficiency of the heating and cooling system.

## Standard Features

- High efficiency **MERV 11 Media Filter** is an extra deep,  $5\frac{1}{4}$  inch filter which contains more media material than other filters on the market. More surface area means more collection area, longer filter life and lower static pressure. Filter lasts up to one year.
- Two, pull-out doors with handle allow filter access from either side.
- Adjustable inlet duct opening replaces need for field forming transition, significantly reducing installation time.
- Heavy 22 gauge galvanized sheet metal has been die cut for smooth edges, allowing for a smoother installation.
- Solid cabinet is riveted for sturdiness and long life.
- Individually boxed for convenient shipping and warehousing.

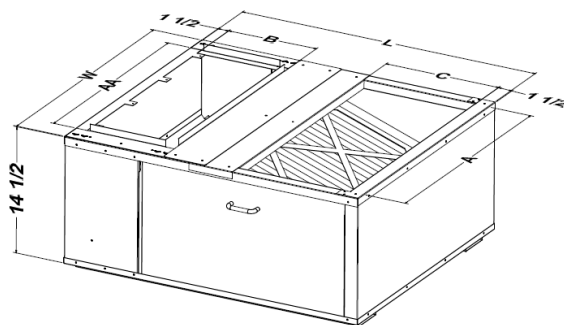

MODEL	W	L	A	AA	B	C	PRESSURE DROP	FILTER SIZE	REPLACEMENT FILTER
<b>EAFB2832-M8</b>	28½	32	26	23¾* 26	8	13¼ - 15¼	.069 (in./wg) @ 246 fpm .207 (in./wg) @ 492 fpm	20 x 25	M8-1056
<b>EAFB2833-M8</b>	28½	33	26	23¾* 26	10	12½ - 15½	.069 (in./wg) @ 246 fpm .207 (in./wg) @ 492 fpm	20 x 25	M8-1056
<b>EAFB2839-M8</b>	28½	39	26	23¾* 26	10	16¾ - 21½	.069 (in./wg) @ 246 fpm .207 (in./wg) @ 492 fpm	20 x 25	M8-1056
<b>EAFB2843-M8</b>	28½	43	26	23¾* 26	10 12	19 - 24½ 19 - 22½	.069 (in./wg) @ 246 fpm .207 (in./wg) @ 492 fpm	20 x 25	M8-1056
<b>EAFB2232-M2</b>	22½	32	20	20	8	14¼ - 16¼	.062 (in./wg) @ 246 fpm .203 (in./wg) @ 492 fpm	20 x 20	M2-1056
<b>EAFB2240-M8</b>	22½	40	20	20	10 12	20 - 22 16½ - 22	.069 (in./wg) @ 246 fpm .207 (in./wg) @ 492 fpm	20 x 25	M8-1056
<b>EAFB2243-M8</b> <b>NEW</b>	22½	43	20	20	10 12	20 - 24¾ 19 - 22½	.069 (in./wg) @ 246 fpm .207 (in./wg) @ 492 fpm	20 x 25	M8-1056

\* Includes removable duct adaptors. Smaller dimension applies when duct adapters are installed.

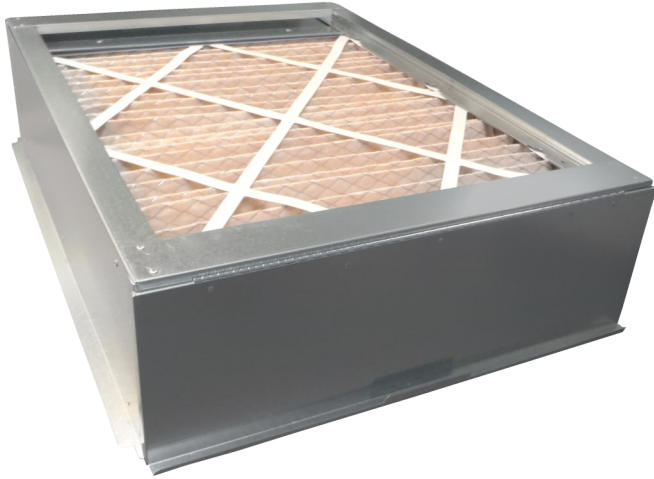

### Standard Features

- Fully hinged door with magnetic latch and integrated handle provides a tight seal, eliminating air and debris from entering the filter box from surrounding area.
- Heavy 22 gauge galvanized sheet metal has smooth edges allowing for a smoother installation.
- Solid cabinet design is spot welded and riveted for sturdiness and long life.
- Tabs have rounded corners.
- Mounting holes are provided for faster installation.
- Individually boxed for convenient shipping and warehousing.

### Description

- The **Air-Tite Series** Filter Housing Media Air Cleaners by Electro-Air offer the most well-built, sleek designed and easiest to use galvanized sheet metal filter housings on the market, for residential and light commercial use.
- Allows for easy access to furnace filters—no panels or door to remove.
- Made to fit electric air handlers.
- Makes a clean and professional installation.
- High efficiency MERV 11 Media Filter is an extra deep, 5¼ inch, 24 pleat filter which contains more media material than other filters on the market. More surface area means more collection area, longer filter life and lower static pressure. Filter lasts up to one year.

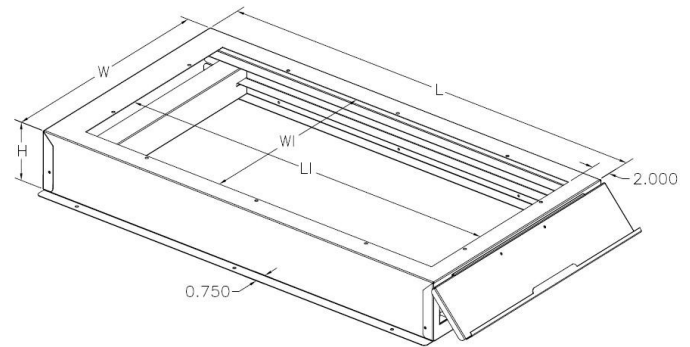

### AIR-TITE HOUSING - FITS 5 ¼" MERV 11 MEDIA FILTERS

MODEL	OUTSIDE DIMENSIONS			OPENING		REPLACEMENT FILTER	FILTER SIZE
	W	H	L	W1	L1		
<b>EAFHE1420-7</b>	15 <sup>5</sup> / <sub>8</sub>	7 <sup>3</sup> / <sub>8</sub>	22 <sup>1</sup> / <sub>8</sub>	12 <sup>7</sup> / <sub>8</sub>	18	MAH-1056A	14 x 22 x 5¼
<b>EAFHE1620-7</b>	17 <sup>3</sup> / <sub>8</sub>	7 <sup>3</sup> / <sub>8</sub>	22 <sup>1</sup> / <sub>8</sub>	14 <sup>5</sup> / <sub>8</sub>	18	MFAH-S	15-7/16 x 21-15/16 x 5¼
<b>EAFHE2020-7</b>	21 <sup>5</sup> / <sub>8</sub>	7 <sup>3</sup> / <sub>8</sub>	22 <sup>1</sup> / <sub>8</sub>	18 <sup>7</sup> / <sub>8</sub>	18	MAH-1056B	19¾ x 22 x 5¼
<b>EAFHE2025-7</b>	26 <sup>5</sup> / <sub>8</sub>	7 <sup>3</sup> / <sub>8</sub>	22 <sup>1</sup> / <sub>8</sub>	23 <sup>3</sup> / <sub>8</sub>	18	M8-1056	20¼ x 25 <sup>3</sup> / <sub>8</sub> x 5¼
<b>EAFHE2025-7N</b>	21 <sup>5</sup> / <sub>8</sub>	7 <sup>3</sup> / <sub>8</sub>	25½	18 <sup>7</sup> / <sub>8</sub>	21 <sup>3</sup> / <sub>8</sub>	M8-1056	20¼ x 25 <sup>3</sup> / <sub>8</sub> x 5¼
<b>EAFHE2224-7</b>	23 <sup>3</sup> / <sub>8</sub>	7 <sup>3</sup> / <sub>8</sub>	24½	20 <sup>5</sup> / <sub>8</sub>	20	MFAH-L	22 <sup>1</sup> / <sub>8</sub> x 24 x 5¼



**EAFHE1420-3**

- Solid cabinet design is spot welded and riveted for sturdiness and long life.
- Tabs have rounded corners.
- Mounting holes are provided for faster installation.
- Individually boxed for convenient shipping and warehousing.

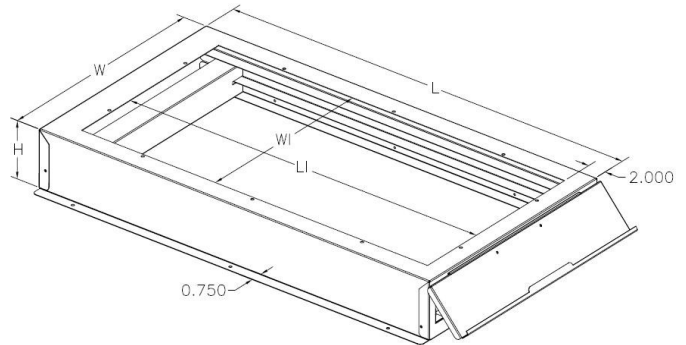

### Description

- The **Air-Tite Series** Filter Housings by Electro-Air offer the most well-built, sleek designed and easiest to use galvanized sheet metal filter housings on the market, for residential and light commercial use.
- Allows for easy access to furnace filters—no panels or door to remove.
- Made to fit all electric air handlers through 5 tons.
- Makes a clean and professional installation.
- Uses standard size pleated or panel filters.

### Standard Features

- Fully hinged door with magnetic latch and integrated handle provide a tight seal, eliminating air and debris from entering the filter box from surrounding area.
- Removable rails are easy to change to accommodate different filter sizes.
- Heavy 22 gauge galvanized sheet metal has been die cut for smooth edges, allowing for a smooth installation.

### AIR-TITE HOUSING - FOR 1" or 2" FILTERS

MODEL	OUTSIDE DIMENSIONS			OPENING		FILTER SIZE
	W	H	L	W1	L1	
<b>EAFHE1420-3</b>	15 $\frac{3}{8}$ "	4"	22"	12 $\frac{3}{8}$ "	18 $\frac{3}{4}$ "	14 x 20
<b>EAFHE1620-3</b>	17 $\frac{3}{8}$ "	4"	22"	14 $\frac{3}{8}$ "	18 $\frac{3}{4}$ "	16 x 20
<b>EAFHE2020-3</b>	21 $\frac{3}{8}$ "	4"	22"	18 $\frac{3}{8}$ "	18 $\frac{3}{4}$ "	20 x 20
<b>EAFHE2020-3T</b>	23 $\frac{1}{2}$ "	4"	22"	19 $\frac{3}{4}$ "	18 $\frac{3}{4}$ "	20 x 20
<b>EAFHE2025-3</b>	26 $\frac{3}{8}$ "	4"	22"	23 $\frac{3}{8}$ "	18 $\frac{3}{4}$ "	20 x 25
<b>EAFHE2025-3N</b>	21 $\frac{3}{8}$ "	4"	25"	18 $\frac{3}{8}$ "	21 $\frac{3}{4}$ "	20 x 25

### AIR-TITE HOUSING - FOR 1" FILTERS

MODEL	OUTSIDE DIMENSIONS			OPENING		FILTER SIZE
	W	H	L	W1	L1	
<b>EAFHE1420-2</b>	15 $\frac{3}{8}$ "	3"	22"	12 $\frac{3}{8}$ "	18 $\frac{3}{4}$ "	14 x 20
<b>EAFHE1620-2</b>	17 $\frac{3}{8}$ "	3"	22"	14 $\frac{3}{8}$ "	18 $\frac{3}{4}$ "	16 x 20
<b>EAFHE2020-2</b>	21 $\frac{3}{8}$ "	3"	22"	18 $\frac{3}{8}$ "	18 $\frac{3}{4}$ "	20 x 20
<b>EAFHE-2025-2</b>	26 $\frac{3}{8}$ "	3"	22"	23 $\frac{3}{8}$ "	18 $\frac{3}{4}$ "	20 x 25
<b>EAFHE2025-2N</b>	21 $\frac{3}{8}$ "	3"	25"	18 $\frac{3}{8}$ "	21 $\frac{3}{4}$ "	20 x 25

### AIR-TITE HOUSING - FOR 1", 2" or 4" FILTERS

MODEL	OUTSIDE DIMENSIONS			OPENING		FILTER SIZE
	W	H	L	W1	L1	
<b>EAFHE1420-6</b>	15 $\frac{3}{8}$ "	6"	22"	12 $\frac{3}{8}$ "	18 $\frac{3}{4}$ "	14 x 20
<b>EAFHE1620-6</b>	17 $\frac{3}{8}$ "	6"	22"	14 $\frac{3}{8}$ "	18 $\frac{3}{4}$ "	16 x 20
<b>EAFHE2020-6</b>	21 $\frac{3}{8}$ "	6"	22"	18 $\frac{3}{8}$ "	18 $\frac{3}{4}$ "	20 x 20
<b>EAFHE2020-6T</b>	23 $\frac{1}{2}$ "	6"	22"	19 $\frac{3}{4}$ "	18 $\frac{3}{4}$ "	20 x 20
<b>EAFHE2025-6</b>	26 $\frac{3}{8}$ "	6"	22"	23 $\frac{3}{8}$ "	18 $\frac{3}{4}$ "	20 x 25
<b>EAFHE2025-6N</b>	21 $\frac{3}{8}$ "	6"	25"	18 $\frac{3}{8}$ "	21 $\frac{3}{4}$ "	20 x 25

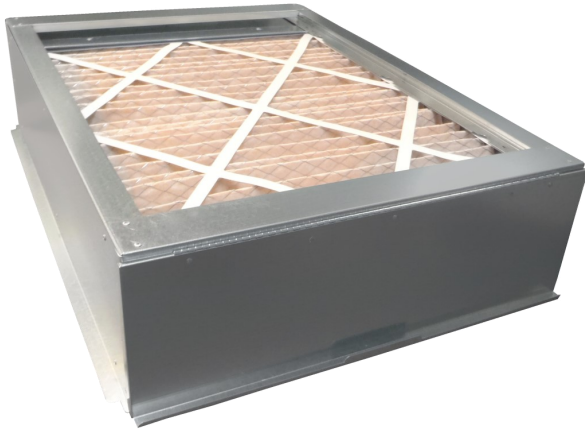

### Standard Features

- Fully hinged door with magnetic latch and integrated handle provides a tight seal, eliminating air and debris from entering the filter box from surrounding area.
- Heavy 22 gauge galvanized sheet metal has smooth edges allowing for a smoother installation.
- Solid cabinet design is spot welded and riveted for sturdiness and long life.
- Tabs have rounded corners.
- Mounting holes are provided for faster installation.
- Individually boxed for convenient shipping and warehousing.

### Description

- The **Air-Tite Series** Filter Housing Media Air Cleaners by Electro-Air offer the most well-built, sleek designed and easiest to use galvanized sheet metal filter housings on the market, for residential and light commercial use.
- Allows for easy access to furnace filters—no panels or door to remove.
- Made to fit gas upflow furnaces.
- Makes a clean and professional installation.
- High efficiency MERV 11 Media Filter is an extra deep, 5¼ inch, 24 pleat filter which contains more media material than other filters on the market. More surface area means more collection area, longer filter life and lower static pressure. Filter lasts up to one year.

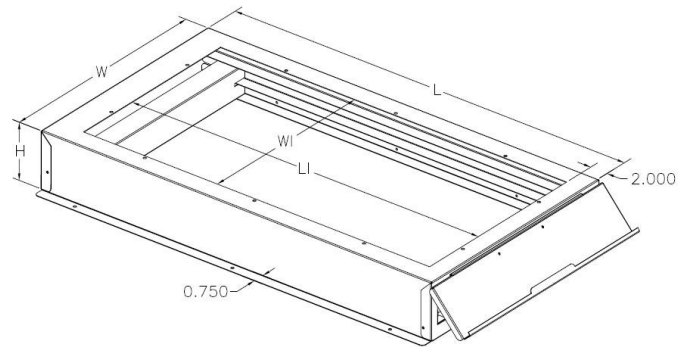

### AIR-TITE HOUSING - FITS 5 ¼" MERV 11 MEDIA FILTERS

MODEL	OUTSIDE DIMENSIONS			OPENING		FILTER SIZE	REPLACEMENT FILTER
	W	H	L	W1	L1		
<b>EAFHG1425-7M1*</b>	17 <sup>3</sup> / <sub>8</sub>	7 <sup>3</sup> / <sub>8</sub>	28 <sup>1</sup> / <sub>2</sub>	12 <sup>5</sup> / <sub>8</sub>	24 <sup>3</sup> / <sub>8</sub>	16 x 25	M1-1056
<b>EAFHG1625-7M1</b>	17 <sup>3</sup> / <sub>8</sub>	7 <sup>3</sup> / <sub>8</sub>	28 <sup>1</sup> / <sub>2</sub>	14 <sup>5</sup> / <sub>8</sub>	24 <sup>3</sup> / <sub>8</sub>	16 x 25	M1-1056
<b>EAFHG2025-7M8</b>	21 <sup>1</sup> / <sub>8</sub>	7 <sup>3</sup> / <sub>8</sub>	28 <sup>1</sup> / <sub>2</sub>	18 <sup>1</sup> / <sub>8</sub>	24 <sup>3</sup> / <sub>8</sub>	20 x 25	M8-1056

\* Use for 14 inch wide furnace only.

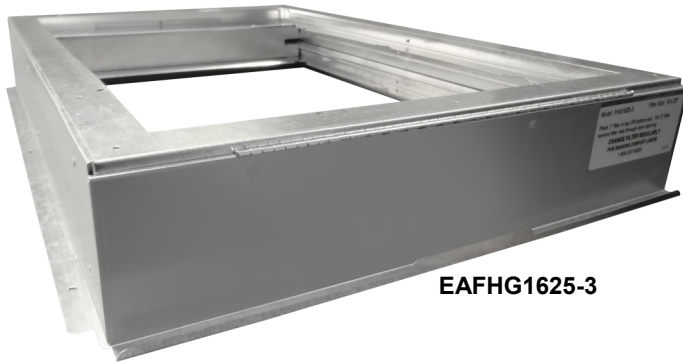

**EAFHG1625-3**

### Description

- The **Air-Tite Series** Filter Housings by Electro-Air offer the most well-built, sleek designed and easiest to use galvanized sheet metal filter housings on the market, for residential and light commercial use.
- Allows for easy access to furnace filters—no panels or door to remove.
- Made to fit all gas furnaces through 5 tons.
- Makes a clean and professional installation.
- Uses standard size pleated or panel filters.

### Standard Features

- Fully hinged door with magnetic latch and integrated handle provides a tight seal, eliminating air and debris from entering the filter box from surrounding area.
- Removable rails are easy to change to accommodate different filter sizes.
- Heavy 22 gauge galvanized sheet metal has been die cut for smooth edges, allowing for a smooth installation.

#### AIR-TITE HOUSING - FOR 1" FILTERS

MODEL	OUTSIDE DIMENSIONS			OPENING		FILTER SIZE
	W	H	L	W1	L1	
<b>EAFHG1425-2</b>	15 $\frac{3}{8}$ "	3"	28 $\frac{1}{2}$ "	12 $\frac{5}{8}$ "	25 $\frac{1}{4}$ "	14 x 25
<b>EAFHG1625-2</b>	17 $\frac{3}{8}$ "	3"	28 $\frac{1}{2}$ "	14 $\frac{5}{8}$ "	25 $\frac{1}{4}$ "	16 x 25
<b>EAFHG2025-2</b>	21 $\frac{3}{8}$ "	3"	28 $\frac{1}{2}$ "	18 $\frac{5}{8}$ "	25 $\frac{1}{4}$ "	20 x 25
<b>EAFHG2424-2</b>	25 $\frac{3}{8}$ "	3"	28 $\frac{1}{2}$ "	22 $\frac{5}{8}$ "	25 $\frac{1}{4}$ "	24 x 24
<b>EAFHG3025-2</b>	31 $\frac{3}{8}$ "	3"	28 $\frac{1}{2}$ "	28 $\frac{5}{8}$ "	25 $\frac{1}{4}$ "	30 x 25

- Solid cabinet design is spot welded and riveted for sturdiness and long life.
- Tabs have rounded corners.
- Mounting holes are provided for faster installation.
- Individually boxed for convenient shipping and warehousing.

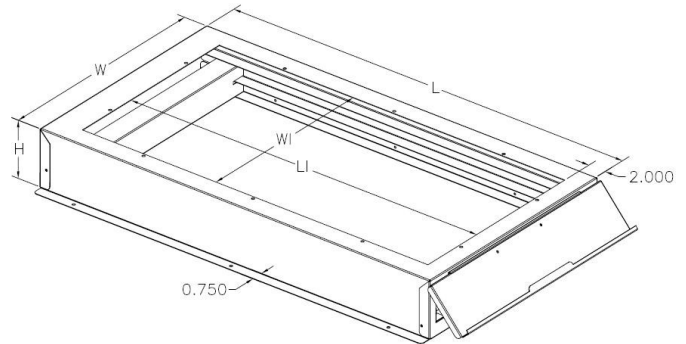

#### AIR-TITE HOUSING - FOR 1" or 2" FILTERS

MODEL	OUTSIDE DIMENSIONS			OPENING		FILTER SIZE
	W	H	L	W1	L1	
<b>EAFHG1425-3</b>	15 $\frac{3}{8}$ "	4"	28 $\frac{1}{2}$ "	12 $\frac{5}{8}$ "	25 $\frac{1}{4}$ "	14 x 25
<b>EAFHG1625-3</b>	17 $\frac{3}{8}$ "	4"	28 $\frac{1}{2}$ "	14 $\frac{5}{8}$ "	25 $\frac{1}{4}$ "	16 x 25
<b>EAFHG2025-3</b>	21 $\frac{3}{8}$ "	4"	28 $\frac{1}{2}$ "	18 $\frac{5}{8}$ "	25 $\frac{1}{4}$ "	20 x 25
<b>EAFHG2424-3</b>	25 $\frac{3}{8}$ "	4"	28 $\frac{1}{2}$ "	22 $\frac{5}{8}$ "	25 $\frac{1}{4}$ "	24 x 24
<b>EAFHG3025-3</b>	31 $\frac{3}{8}$ "	4"	28 $\frac{1}{2}$ "	28 $\frac{5}{8}$ "	25 $\frac{1}{4}$ "	30 x 25

#### AIR-TITE HOUSING - FOR 1", 2" or 4" FILTERS

MODEL	OUTSIDE DIMENSIONS			OPENING		FILTER SIZE
	W	H	L	W1	L1	
<b>EAFHG1425-6</b>	15 $\frac{3}{8}$ "	6"	28 $\frac{1}{2}$ "	12 $\frac{5}{8}$ "	25 $\frac{1}{4}$ "	14 x 25
<b>EAFHG1625-6</b>	17 $\frac{3}{8}$ "	6"	28 $\frac{1}{2}$ "	14 $\frac{5}{8}$ "	25 $\frac{1}{4}$ "	16 x 25
<b>EAFHG2025-6</b>	21 $\frac{3}{8}$ "	6"	28 $\frac{1}{2}$ "	18 $\frac{5}{8}$ "	25 $\frac{1}{4}$ "	20 x 25
<b>EAFHG2424-6</b>	25 $\frac{3}{8}$ "	6"	28 $\frac{1}{2}$ "	22 $\frac{5}{8}$ "	25 $\frac{1}{4}$ "	24 x 24
<b>EAFHG3025-6</b>	31 $\frac{3}{8}$ "	6"	28 $\frac{1}{2}$ "	28 $\frac{5}{8}$ "	25 $\frac{1}{4}$ "	30 x 25





**NEW**



### Description

- Designed for downflow air handlers or furnaces up to 5 ton.
- Solid construction, sleek design and easy to install for residential and light commercial use.
- Takes 1" or 4<sup>3</sup>/<sub>8</sub>" pleated or panel filters.
- Available with or without filter.

### Standard Features

- Fully hinged door with magnetic latch, integrated handle and corner notches to eliminate any chance of the door hanging up on the plenum.
- Solid one-piece 22 gauge galvanized wrap offers a much tighter seal than other competitor cabinets and has been die cut for smooth edges.
- Individually boxed.

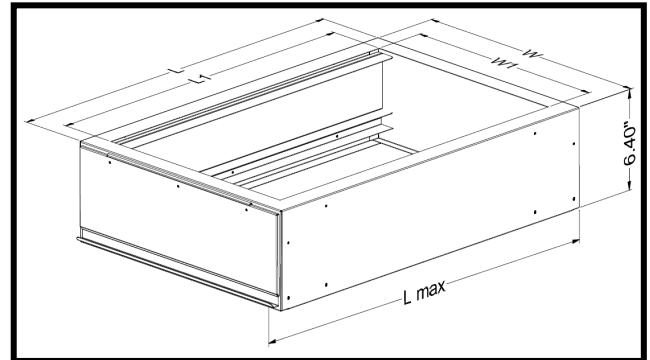

MODEL	FITS FURNACES OR AIR HANDLERS	OUTSIDE DIMENSIONS			L MAX	OPENING		FILTER SIZE	REPLACEMENT FILTER	WEIGHT (lbs)
		W	H	L		W	L			
<b>EACFHG1420-6</b>	14x20	21	6	17½	20 5/8	18½	15	14 x 20 x 1	n/a	9.0
<b>EACFHG1620-6</b>	16x20	21	6	17½	20 5/8	18½	15	16 x 20 x 1 15 <sup>7</sup> / <sub>8</sub> x 19 <sup>3</sup> / <sub>4</sub> x 4 <sup>3</sup> / <sub>8</sub>	MFH-1620-4	9.5
<b>EACFHG1625-6</b>	16x25	21	6	21	25 5/8	18½	18½	16 x 25 x 1 15 <sup>7</sup> / <sub>8</sub> x 24 <sup>3</sup> / <sub>4</sub> x 4 <sup>3</sup> / <sub>8</sub>	MFH-1625-4	10.0
<b>EACFHG2020-6</b>	20x20	21	6	21	20 5/8	18½	18½	20 x 20 x 1 19 <sup>7</sup> / <sub>8</sub> x 19 <sup>3</sup> / <sub>4</sub> x 4 <sup>3</sup> / <sub>8</sub>	MFH-2020-4	10.5
<b>EACFHG2025-6</b>	20x25	21	6	24½	25 5/8	18½	22	20 x 25 x 1 19 <sup>7</sup> / <sub>8</sub> x 24 <sup>3</sup> / <sub>4</sub> x 4 <sup>3</sup> / <sub>8</sub>	MFH-2025-4	11.0



**ELECTRO-AIR CANADA**  
 351 North Rivermede Road, Concord, Ontario, Canada L4K 3N2  
 Tel: (416) 213-5636 Fax: (416) 213-5593  
 Toll Free: (800) 267-8305  
[info@fiveseasonsaircleaners.com](mailto:info@fiveseasonsaircleaners.com) [www.fiveseasonsaircleaners.com](http://www.fiveseasonsaircleaners.com)





**NEW**

**Standard Features**

- Heavy 22 gauge galvanized sheet metal cabinet, available in three sizes.
- Solid one piece wrap cabinet is riveted for sturdiness and long life.
- Available in galvanized sheet metal or powder coat paint finish (Galvanized - G, Painted - P).
- Individually boxed.

**Description**

- The Plenum Access Coil Cases for gas furnaces are the perfect solution for allowing easy cleaning and maintenance of the Air Conditioning coil.
- Saves hours of time. No need to take system or duct work apart.
- Two access doors allow quick access to the coil.
- Space saving design makes for a cleaner, more professional installation.

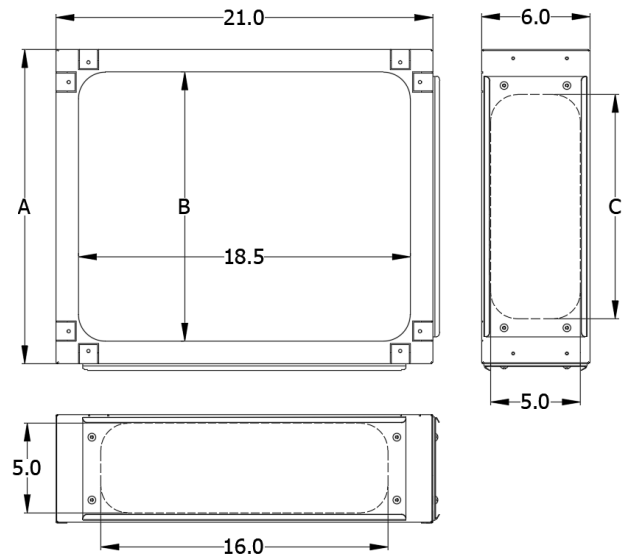

MODEL	FINISH	OUTSIDE DIMENSIONS			FRONT ACCESS DOOR	SIDE ACCESS DOOR	INSIDE DIMENSIONS		WEIGHT (lbs)
		W	H	L			W	L	
<b>EACC1721-G</b>	Galvanized	21	6	17½	14	18	18½	15	6
<b>EACC1721-P</b>	Painted	21	6	17½	14	18	18½	15	6
<b>EACC2121-G</b>	Galvanized	21	6	21	18	18	18½	18½	7
<b>EACC2121-P</b>	Painted	21	6	21	18	18	18½	18½	7
<b>EACC2421-G</b>	Galvanized	21	6	24½	21	18	18½	22	8
<b>EACC2421-P</b>	Painted	21	6	24½	21	18	18½	22	8



**ELECTRO-AIR CANADA**  
 351 North Rivermede Road, Concord, Ontario, Canada L4K 3N2  
 Tel: (416) 213-5636 Fax: (416) 213-5593  
 Toll Free: (800) 267-8305  
[info@fiveseasonsaircleaners.com](mailto:info@fiveseasonsaircleaners.com) [www.fiveseasonsaircleaners.com](http://www.fiveseasonsaircleaners.com)





**Fits most 4"-5" Media Air Cleaners.....**

- Honeywell
- Aprilaire
- Amana
- Carrier
- Clean Comfort
- Daikin
- Field Controls
- Goodman
- Lennox
- Skuttle
- Trion
- Ultravation
- White Rodgers

- Fits most major brands of Air Cleaners.
- High Efficiency MERV\* 11 Media Filter, rated at 492 feet/minute, removes airborne contaminants down to 0.3 micron.
- Filter material is constructed of continuous hydrophobic polyolefin fibers that will not shred or absorb moisture. They are cellulose free and will not sustain mold growth.
- Unique filter design features a structured density gradient with an electret charge for higher initial and sustained efficiency over the life of the filter.

- Deep, 4<sup>3</sup>/<sub>8</sub> inch filter contains more media material than other filters on the market. More surface area means more collection area, longer filter life and lower static pressure.
- Approximately 2-4 times the dust holding capacity of most filters.
- Filter will last up to one year in standard applications.
- Cost advantage over competitor filters.

\* MERV: Minimum Efficiency Reporting Value. Based on ASHRAE Standard 52.2.

PART NUMBER	NOMINAL SIZE (Inch)	ACTUAL SIZE (inch)			RATED CAPACITY	STATIC PRESSURE (inches)
		Height	Length	Width		
<b>MFH-1620-4</b>	16 x 20	15 <sup>7</sup> / <sub>8</sub>	19 <sup>3</sup> / <sub>4</sub>	4 <sup>3</sup> / <sub>8</sub>	1200	0.213
<b>MFH-1625-4</b>	16 x 25	15 <sup>7</sup> / <sub>8</sub>	24 <sup>3</sup> / <sub>4</sub>	4 <sup>3</sup> / <sub>8</sub>	1400	0.205
<b>MFH-2020-4</b>	20 x 20	19 <sup>7</sup> / <sub>8</sub>	19 <sup>3</sup> / <sub>4</sub>	4 <sup>3</sup> / <sub>8</sub>	1400	0.220
<b>MFH-2025-4</b>	20 x 25	19 <sup>7</sup> / <sub>8</sub>	24 <sup>3</sup> / <sub>4</sub>	4 <sup>3</sup> / <sub>8</sub>	2000	0.189



- Fits over 20 major furnace brands of air cleaning equipment including Clean Comfort, Goodman, Amana, Daikin, Carrier, Totaline, Rheem, Rhuud, York, Coleman, Source 1, Tappan, Philco, Frigidaire, Nutone, Broan, Westinghouse, Kelvinator, Napoleon, Continental, Electro-Air, Five Seasons, and lots more.
- High Efficiency MERV\* 11 Media Filter, rated at 492 feet/minute, removes airborne contaminants down to 0.3 micron.
- Filter material is constructed of continuous hydrophobic polyolefin fibers that will not shred or absorb moisture. They are cellulose free and will not sustain mold growth.
- Unique filter design features a structured density gradient with an electret charge for higher initial and sustained efficiency over the life of the filter.

- Deep, 5¼ inch filter contains more media material than other filters on the market. More surface area means more collection area, longer filter life and lower static pressure.
- Have perfect fit with the air cleaner models listed below.
- Filter will last up to one year in standard applications.
- Cost advantage over competitor filters, including knock-off market.
- Exclusively sold through the HVAC industry, not the big box stores.
- Filters are Made in Canada, whereas most filters on market are coming from Mexico or China.

\* MERV: Minimum Efficiency Reporting Value. Based on ASHRAE Standard 52.2.

PART NUMBER	NOMINAL SIZE (Inch)	ACTUAL SIZE (inch)			PRESSURE DROP	FITS AIR CLEANER MODELS
		Height	Length	Width		
<b>M0-1056</b>	16 x 20	15 <sup>3</sup> / <sub>8</sub>	21 <sup>7</sup> / <sub>8</sub>	5 <sup>1</sup> / <sub>4</sub>	.064 (in./wg) @ 246 fpm .209 (in./wg) @ 492 fpm	EAMU1620-A, EANC1620-A
<b>M1-1056</b>	16 x 25	15 <sup>3</sup> / <sub>8</sub>	25 <sup>1</sup> / <sub>2</sub>	5 <sup>1</sup> / <sub>4</sub>	.066 (in./wg) @ 246 fpm .217 (in./wg) @ 492 fpm	EAMA11-1728-FA, EAMU1625-A, EANC1625-A
<b>M2-1056</b>	20 x 20	20 <sup>1</sup> / <sub>4</sub>	20 <sup>3</sup> / <sub>4</sub>	5 <sup>1</sup> / <sub>4</sub>	.062 (in./wg) @ 246 fpm .203 (in./wg) @ 492 fpm	EAMA11-2122-AA, EAMU2020-A, EANC2020-A
<b>M8-1056</b>	20 x 25	20 <sup>1</sup> / <sub>4</sub>	25	5 <sup>1</sup> / <sub>4</sub>	.069 (in./wg) @ 246 fpm .207 (in./wg) @ 492 fpm	EAMA11-2128-FA, EAMA11-2428-FA, EAMU2025-A, EARAM2000, EANC2025-A, EANC2520-A
<b>MFAH-S</b>	15 x 22	15 <sup>1</sup> / <sub>2</sub>	22	5 <sup>1</sup> / <sub>4</sub>	.066 (in./wg) @ 246 fpm .217 (in./wg) @ 492 fpm	EAMA11-1722-AA, EAFHE1620-7
<b>MFAH-M</b>	19 x 22	19 <sup>9</sup> / <sub>16</sub>	22	5 <sup>1</sup> / <sub>4</sub>	.062 (in./wg) @ 246 fpm .203 (in./wg) @ 492 fpm	EAMA11-2022-AC, EAFHE1620-7
<b>MFAH-L</b>	24 x 22	24	22	5 <sup>1</sup> / <sub>4</sub>		EAFHE2224-7
<b>MAH-1056A</b>	14 x 22	14	22	5 <sup>1</sup> / <sub>4</sub>	.064 (in./wg) @ 246 fpm .209 (in./wg) @ 492 fpm	EAMA11-1428-FA, EAMA11-1422-AA, EAFHE1420-7
<b>MAH-1056B</b>	20 x 22	19 <sup>3</sup> / <sub>4</sub>	22	5 <sup>1</sup> / <sub>4</sub>		EAFHE2020-7
<b>MAH-1056C</b>	22 x 22	22 <sup>1</sup> / <sub>4</sub>	22	5 <sup>1</sup> / <sub>4</sub>	.069 (in./wg) @ 246 fpm .207 (in./wg) @ 492 fpm	EAMA11-2422-AA



- Fits over 20 major furnace brands of air cleaning equipment including Clean Comfort, Goodman, Amana, Daikin, Carrier, Totaline, Rheem, Rhuud, York, Coleman, Source 1, Tappan, Philco, Frigidaire, Nutone, Broan, Westinghouse, Kelvinator, Napoleon, Continental, Electro-Air, Five Seasons, and lots more.
- High Efficiency MERV\* 14 Media Filter, rated at 492 feet/minute, removes airborne contaminants down to 0.3 micron.
- The Green Series Media Material is designed to meet the air filtration efficiency criteria required to gain points toward certification in the Leadership in Energy and Environmental Design (LEED) Green Building rating system.
- Filter material is constructed with an advanced synthetic air media that utilizes both charged fibers and traditional mechanical filtration principles. The charged fibers allow the media to achieve MERV 14 levels upon installation and immediately grab and trap

airborne contaminants. The resulting dust cake then enhances the mechanical principles of the filter allowing for high levels of filtration during the entire life-cycle.

- Deep, 5¼ inch filter contains more media material than other filters on the market. More surface area means more collection area, longer filter life and lower static pressure.
- Have perfect fit with the air cleaner models listed below.
- Filter will last up to one year in standard applications.
- Exclusively sold through the HVAC industry, not the big box stores.
- Filters are manufactured from premium Europe and American materials.

\* **MERV:** Minimum Efficiency Reporting Value. Based on ASHRAE Standard 52.2.

PART NUMBER	NOMINAL SIZE (Inch)	ACTUAL SIZE (inch)			EFFICIENCY On Micron Size	PRESSURE DROP	FITS AIR CLEANER MODELS
		Height	Length	Width			
<b>G1-1056</b>	16 x 25	15⅜	25½	5¼	E1 (.3-1 micron) 82% E2 (1-3 micron) 97% E3 (3-10 micron) 99%	.10 (in./wg) @ 684 cfm .28 (in./wg) @ 1367 cfm	EAMA11-1728-FA, EAMU1625-A, EA14MU1625-A, EANC1625-A, EAMEDIA-1625-TL, EAMF3225
<b>G8-1056</b>	20 x 25	20¼	25	5¼	E1 (.3-1 micron) 85% E2 (1-3 micron) 98% E3 (3-10 micron) 99%	.09 (in./wg) @ 854 cfm .24 (in./wg) @ 1708 cfm	EAMA11-2128-FA, EAMA11-2428-FA, EAMU2025-A, EA14MU2025-A, EARAM2000, EANC2025-A, EANC2520-A

Part #9900  
32 oz (1 L)  
Spray Bottle



Part #9902  
1 gallon (4.4 L)  
Jug

- DAX is ideal for all types of Electronic Air Cleaners, whether furnace-mount or portable.
- Strips pollutants away from electronic collecting cells and lint screen prefilters, in just 5 minutes.
- It's the fastest, most economical and sanitary maintenance method of removing pollutants from collecting cells and prefilters.
- DAX can also be used for cleaning kitchen exhaust grease filters, air conditioning coils, white-wall tires, venetian blinds, patio furniture, tile grout or wherever there is tough household dirt.
- DAX is a non-abrasive, non-corrosive, non-toxic, industrial degreaser.
- Using detergents other than DAX may cause collecting cells to arc excessively, turn black, rust or have a fine white dust powder accumulation.
- Do not wash collecting cells in dishwasher as the tines and high heat may cause the plates or ionizing wires to warp, which may cause arcing.
- Do not dry collecting cells in oven.
- DAX is available in 32 oz, 1 gallon, 5 gallon and 45 gallon drums.
- Material Safety Data Sheets available upon request.